

Pump element type MPE and PE for radial piston pumps

Product documentation



Operating pressure p_{\max} :	700 bar
Geometric displacement $V_{g \max}$:	1.52 cm ³ /rev
Flow rate Q_{\max} :	2.2 lpm (1450 rpm)
	4.2 lpm (2850 rpm)



© by HAWE Hydraulik SE.

The reproduction and distribution of this document as well as the use and communication of its contents to others without explicit authorisation is prohibited.

Offenders will be held liable for the payment of damages.

All rights reserved in the event of patent or utility model applications.

Brand names, product names and trademarks are not specifically indicated. In particular with regard to registered and protected names and trademarks, usage is subject to legal provisions.

HAWE Hydraulik respects these legal provisions in all cases.

Printing date / document generated on: 26.10.2020

Contents

1	Overview of pump elements type MPE and PE for radial piston pumps.....	4
2	Available versions, main data.....	5
2.1	Order coding.....	5
2.2	Available version type MPE and PE.....	5
2.3	Cylinder arrangement.....	7
3	Parameters.....	8
4	Dimensions.....	9
4.1	Standard version.....	9
4.2	Special versions.....	10
5	Assembly, operation and maintenance recommendations.....	11
5.1	Intended use.....	11
5.2	Assembly information.....	11
5.3	Operating instructions.....	12
5.4	Maintenance information.....	12
6	Other information.....	13
6.1	Functional description.....	13

1 Overview of pump elements type MPE and PE for radial piston pumps

The pump elements type MPE and PE deliver lubricating hydraulic fluids while simultaneously generating a counter-pressure opposing the load resistance of a connected consumer.

The pump elements type MPE and PE are the cornerstone of all HAWE radial piston pumps.

High-pressure pumps for various requirements can be constructed using pump elements and suitable drive components.

Features and benefits:

- available as individual unit
- universal usage
- suited to high pressures of up to 700 bar

Intended applications:

- Machine tools
- Devices for workpiece clamping
- Hydraulic tools



Pump element

2 Available versions, main data

2.1 Order coding

Order coding example:

MPE	5	- HC
		Supplement "Table 2"
		Piston diameter
Type		"Table 1"

2.2 Available version type MPE and PE

Table 1 Type

Type	Piston \varnothing	Geometric displacement V_g (cm ³ /rev)	Flow rate Q (lpm) *		Piston force in stroke direction per 1 bar (N)	Power required per 100 bar (kW)		p_{max} (bar)
			1450 rpm	2850 rpm		1450 rpm	2850 rpm	
MPE	4	0.062	0.09	0.18	1.26	0.018 k	0.033 k	700
	5	0.096	0.14	0.27	1.96	0.026 k	0.050 k	700
	6	0.14	0.2	0.4	2.83	0.036 k	0.073 k	700
	7	0.19	0.28	0.54	3.85	0.050 k	0.10 k	700
	8	0.25	0.36	0.71	5.03	0.070 k	0.13 k	700
	9	0.31	0.45	0.89	6.36	0.087 k	0.17 k	550
PE	6	0.21	0.3	0.6	2.83	0.055 k	0.12 k	700
	7	0.29	0.4	0.8	3.90	0.07 k	0.16 k	700
	8	0.38	0.5	1.0	5.03	0.09 k	0.18 k	700
	10	0.59	0.8	1.6	7.85	0.15 k	0.29 k	560
	12	0.84	1.2	2.4	11.3	0.22 k	0.44 k	390
	13	1.0	1.45	2.8	13.3	0.26 k	0.52 k	330
	14	1.15	1.7	3.3	15.4	0.31 k	0.63 k	290
	15	1.32	1.9	3.7	17.7	0.35 k	0.70 k	250
16	1.52	2.2	4.2	20.0	0.43 k	0.84 k	220	

k = Correction factor for number of cylinders and non-uniformity

* At full stroke h_{max} and $\eta_{Vol.} \approx 0.95$

- MPE: $h_{max} = 5$ mm
- PE: $h_{max} = 7.6$ mm

i NOTE

The max. permissible operating pressure refers to the pump element itself. The lifetime-limiting variable generally depends on the load on the bearings (in combination with radial ball bearings). Observe permissible shaft load.

Lifetime of bearings:

$$L_h = \left(\frac{\pi \cdot C_{dyn.} \cdot \eta_{mechan.} \cdot e}{50 \cdot V_g \cdot p} \right)^3 \cdot \frac{10^6}{n \cdot 60}$$

Operating pressure with desired lifetime of bearings:

$$p = \frac{\pi \cdot C_{dyn.} \cdot \eta_{mechan.} \cdot e}{1.96 \cdot V_g \cdot \sqrt[3]{L_h \cdot n}}$$

- L_h = Lifetime in h
- $C_{dyn.}$ = Dynamic load capacity of bearing in N
- $\eta_{mechan.}$ = Mechanical efficiency (approx. 0.85)
- e = Eccentricity in mm
- V_g = Displacement volume in cm^3
- p = Operating pressure in bar
- n = Rotation speed in rpm

Table 2 Special versions

Type	Order coding example	Version	Note
PE 6-HFA PE 7-HFA PE 8-HFA PE 10-HFA PE 12-HFA	PE 10-HFA	For low-viscosity fluids (e.g. HFA or conditioned water)	Surface nitrided Reduced efficiency due to low viscosity For dimensions, see Standard version
MPE 4...9-PYD PE 6...16-PYD	MPE 4-PYD	With seals made from FKM (Viton)	For dimensions, see Standard version
MPE 4...9-AT PE 6...16-AT	PE 12-AT	With seals made from EPDM (e.g. for brake fluid or Skydrol)	For dimensions, see Standard version
MPE 4...9-HC	MPE 6-HC	Without suction strainer	The hydraulic fluid must be filtered using a wire mesh with a mesh size of 0.5 mm (as per ISO 4783-2) as the minimum requirement.
MPE 4...9-HC compl. PE 6...16-HC34 compl. PE 6...16-HC32 compl.	MPE 6-HC compl.	With additional suction pipe	Used e.g. with type HC(W) as per D 7900 with horizontal arrangement
PE 6...16-HKL compl.	PE 12-HKL compl.	With additional suction pipe	Used e.g. with type HKL(W) as per D 7600-3L

2.3 Cylinder arrangement

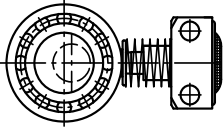
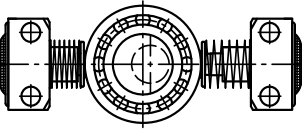
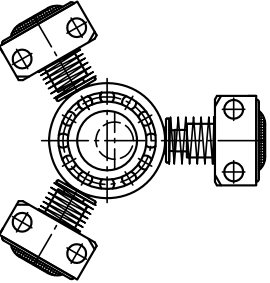
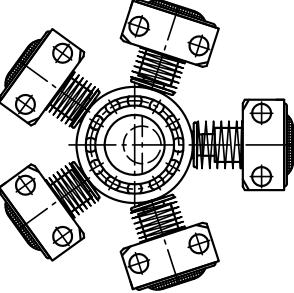
Number of cylinders	Correction factor k	
1	3	
2	1.5	
3 - 4	1	
5 - 7	1	

3 Parameters

General information

Description	Pump element
Design	Valve-controlled pump element
Installation position	As desired The suction valve inlet of the pump element must be entirely below the oil level to prevent any air being drawn in. The piston and roller bearings must be fully immersed under the oil level during continuous operation to ensure continuous lubrication.
Material	Steel; hardened, ground functional inner parts
Hydraulic fluid	Hydraulic oil: according to DIN 51 524 Part 1 to 3; ISO VG 10 to 68 according to DIN 51 519 Viscosity range: min. approx. 4; max. approx. 800 mm ² /s Optimal operating range: approx. 10 ... 500 mm ² /s Also suitable for biologically degradable pressure fluids type HEPG (polyalkylene glycol) and HEES (synthetic ester) at operating temperatures up to approx. +70°C.
cleanliness level	Recommended purity as per ISO 4406, see oil recommendations D 5488/1
Temperatures	Ambient: approx. -40 ... +80°C, Fluid: -25 ... +80°C, Note the viscosity range! Start temperature: down to -40°C is permissible (observe start viscosities!), as long as the steady-state temperature is at least 20K higher during subsequent operation. Biologically degradable pressure fluids: Observe manufacturer's specifications. By consideration of the compatibility with seal material not over +70°C.

Pressure and volumetric flow

Operating pressure	$p_{\max} = 700 \text{ bar}$ (loss of efficiency at $p \leq 20 \text{ bar}$)
Efficiency	$\eta_{\text{vol}} \sim 0.95$
Volumetric flow	See Chapter 2.2, "Available version type MPE and PE"
Perm. stroke frequency	min. 200 rpm max. 2850 rpm Below min. stroke frequency: volumetric efficiency will drop swiftly. Above max. stroke frequency: suction problems may occur (with small cylinder diameters).

Weight

MPE 4 ... 9	90 g
PE 6 ... 16	300 g

4 Dimensions

All dimensions in mm, subject to change.

4.1 Standard version

MPE, PE

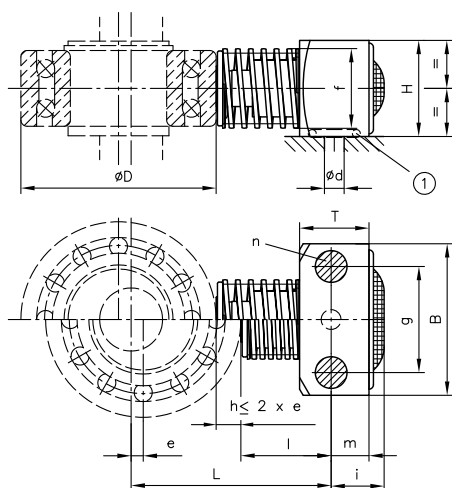

1 O-ring

Type	B	H	T	Ød	e	f	g ±0.1	i	l	m	n	O-ring NBR 90 Shore
MPE 4 ... 9	32	19.7 ^{-0.04}	16	3	2.5 ^{+0.05}	18.5	24	11	20	8	M6-8.8 (9 Nm)	8x2
PE 6 ... 16	50	31.7 ±0.02	22.9	6	3.8 ^{+0.05}	26	35	18.1	30.2	12.5	M10-8.8 (48 Nm)	12.37x2.62

NOTE

- The max. permissible piston stroke must not be exceeded.
- With type MPE: e = 3 mm possible if ØD = 47 mm and L = 46.5 (±0.1 mm). The values for the power required (see [Chapter 2.2, "Available version type MPE and PE"](#)) should then be multiplied by a factor of 1.2.
- Observe reference dimension L to prevent damage to the suction valve (piston dead centre too low).

If roller bearing diameter D differs: recalculate distance:

$$L \pm 0,1 = e + \frac{D}{2} + l \text{ (mm)}$$

Type	Eccentric bearing DIN 628	ØD	Distance L ± 0.1
MPE	3204	47	46
PE	3205	52	60
PE	3206	62	65
PE	3207	72	70
PE	3208	80	74

4.2 Special versions

Version without suction pipe:

MPE..- HC
PE..-HC

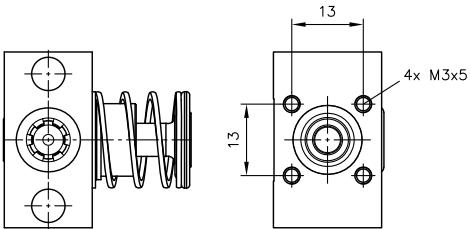

Version with additional suction pipe:

MPE..- HC compl.
PE..-HC (HKL) compl.

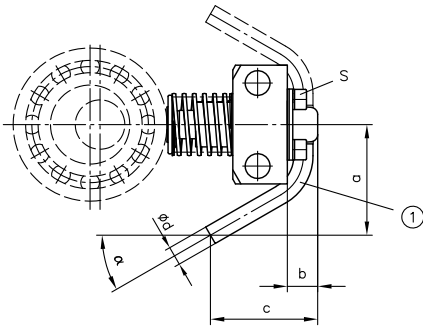

1 Can be installed to right and left

Type	a	b	c	Ød	α	S
MPE 4...9-HC compl.	74	8	39	6x0.8	45°	4x M3x6
PE 6...16-HC34 compl.	70	13	100	8x1	30°	4x M5x10
PE 6...16-HC32 compl.	80	20	55	12x1	60°	2x M5x16 2x M5x25
PE 6...16-HKL compl.	47	13	45	8x1	45°	4x M5x10

All other dimensions [See "Standard version"](#)

5 Assembly, operation and maintenance recommendations

5.1 Intended use

This pump is exclusively intended for hydraulic applications (fluid engineering).

The user must observe the safety measures and warnings in this documentation.

Essential requirements for the product to function correctly and safely:

- All information in this documentation must be observed. This applies in particular to all safety measures and warnings.
- The product must only be assembled and put into operation by qualified personnel.
- The product must only be operated within the specified technical parameters. The technical parameters are described in detail in this documentation.
- All components must be suitable for the operating conditions in the event of application in an assembly.
- The operating and maintenance manual of the components, assemblies and the specific complete system must also always be observed.

If the product can no longer be operated safely:

1. Remove the product from operation and mark it accordingly.
- ✓ It is then not permitted to continue using or operating the product.

5.2 Assembly information



DANGER

Risk to life caused by sudden movement of the hydraulic drives when dismantled incorrectly!

Risk of serious injury or death.

- Depressurise the hydraulic system.
- Perform safety measures in preparation for maintenance.

5.3 Operating instructions

Purity and filtering of the hydraulic fluid

Fine contamination can significantly impair the function of a hydraulic component. Contamination can cause irreparable damage.

Examples of fine contamination include:

- Swarfs
- Rubber particles of hoses and seals
- Dirt due to mounting and maintenance
- Mechanical debris
- Chemical ageing of the hydraulic fluid

! **NOTE**

Fresh hydraulic fluid from the drum does not always have the necessary degree of purity.
Before using hydraulic fluid, filter it.

Adhere to the cleanliness level of the hydraulic fluid in order to maintain faultless operation.
(Also see cleanliness level in [Chapter 3, "Parameters"](#))

Additionally applicable document: [D 5488/1](#) Oil recommendations

5.4 Maintenance information

This product is maintenance-free.

6 Other information

6.1 Functional description

Drive type: motor via rotating shaft

Shaft rotation direction: any (direction of delivery remains unchanged)

A roller bearing is mounted eccentrically on the shaft. The outer race of the bearing acts on the back of the pump element.

This generates the lifting movement in conjunction with the return spring.

The flow rate is controlled by automatic suction and pressure control valves in the housing of the pump element.

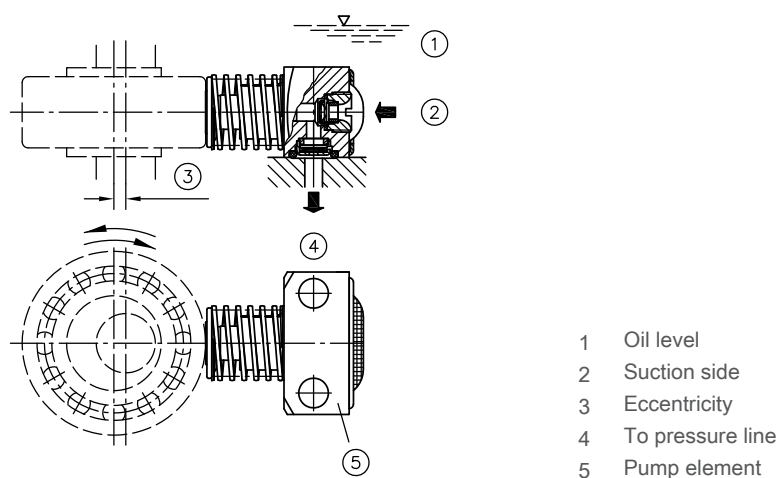

Further information

Additional versions

- Radial piston pump type R and RG: D 6010
- Double pump element type DMPE: D 5600 D