

Radial piston pump type R and RG

Product documentation



Operating pressure p_{\max} :	700 bar
Geometric displacement $V_{g \max}$:	64.2 cm ³ /rev
Flow rate Q_{\max} :	91.2 lpm



© by HAWE Hydraulik SE.

The reproduction and distribution of this document as well as the use and communication of its contents to others without explicit authorisation is prohibited.

Offenders will be held liable for the payment of damages.

All rights reserved in the event of patent or utility model applications.

Brand names, product names and trademarks are not specifically indicated. In particular with regard to registered and protected names and trademarks, usage is subject to legal provisions.

HAWE Hydraulik respects these legal provisions in all cases.

Printing date / document generated on: 13.10.2020

Contents

1	Overview of radial piston pump type R and RG.....	4
1.1	Application.....	4
1.2	Basic types.....	4
1.3	Design.....	5
1.4	Assemblies.....	5
1.5	Sectional model of a double radial pump (assembly 6012).....	5
2	Available versions, main data.....	6
2.1	Order coding.....	6
2.2	Pump types and combinations.....	6
2.3	Motor.....	11
3	Parameters.....	12
4	Dimensions.....	16
4.1	Assembly 7631.....	16
4.2	Assembly 6010.....	16
4.3	Assembly 6011.....	17
4.4	Assembly 6012.....	17
4.5	Assembly 6014.....	18
4.6	Assembly 6016.....	18
5	Installation, operating, and disposal instructions.....	19
5.1	Intended use.....	19
5.2	Assembly information.....	19
5.2.1	Venting and commissioning.....	19
5.2.2	Version for slightly charged pumps (above approx. 0.4 ... 0.5 bar).....	20
5.3	Operating instructions.....	21
5.4	Disposal information.....	21
6	Other information.....	22
6.1	Accessories, spare parts and separate components.....	22

1 Overview of radial piston pump type R and RG

The radial piston pump type R and RG is versatile and can be used not only as a motor pump outside an oil tank but also for installation in the tank of a hydraulic power pack (see [D 6010 H](#)). The radial piston pump type RG has plain bearings which have a longer lifetime. This type is therefore used in extreme operating conditions. Extremely high flow rates can also be achieved by arranging up to 6 radials in parallel.

Features and benefits:

- Good function even at low viscosity
- High level of efficiency
- Compact dimensions
- Fine delivery flow gradation

Intended applications:

- Any high-pressure application is basically possible.
- Areas in which a constant flow rate is necessary.
- Press construction
- Fixture design
- Testing and laboratory equipment
- Lubrication systems
- Agricultural engineering



Radial piston pump type R and RG

1.1 Application

The pumps are generally used to supply hydraulic oil to hydraulic consumers in oil-hydraulic systems. Maximum installable capacity of up to 30 kW, depending on size.

1.2 Basic types

- R** - Classic version with roller bearing as eccentric bearing, also suitable for very low rotation speeds
- RG** - Version with plain bearings as eccentric bearings, well suited to media with low lubricity (e.g. HFC), not suitable for low rotation speeds as the necessary lubricant film cannot be built up.

1.3 Design

The radial piston pumps are valve-controlled with cylinders in a radial arrangement. The cylinder radials, arranged in one, two or more superimposed layers (rows), are driven by bearings fitted eccentrically on the drive shaft (piston pressure stroke), and reset by springs (piston suction stroke). The flow rates of the individual cylinders are brought together in collecting plates feeding a joint pressure connection. The housing shells are load-bearing elements supporting the cylinders and shaft bearings. The pumps are largely statically and dynamically balanced, resulting in smooth running. With the exception of the 1 and 2-cylinder pumps, an uneven number of pistons is used per cylinder radial, so that the pulsation of the flow rate is minimised from three cylinders upwards.

1.4 Assemblies

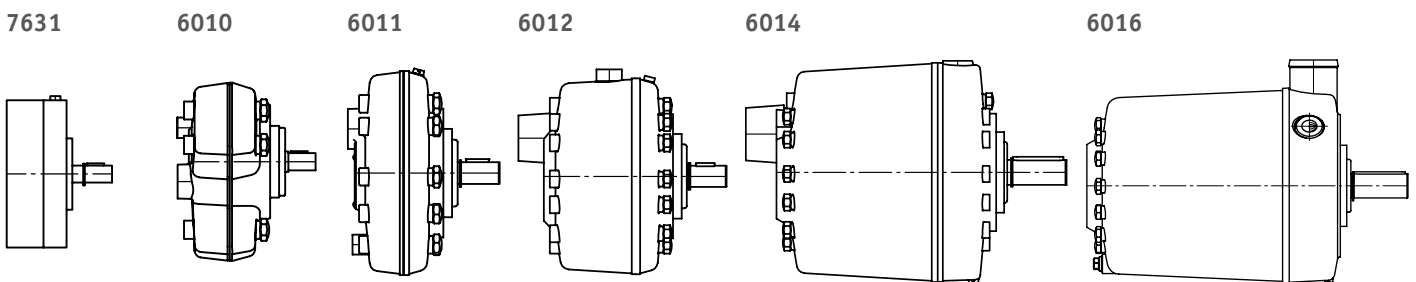

Type MPE.. cylinders are installed in assembly 7631. All other assemblies (type 6010 – 6016) are fitted with type PE.. cylinders.

1.5 Sectional model of a double radial pump (assembly 6012)

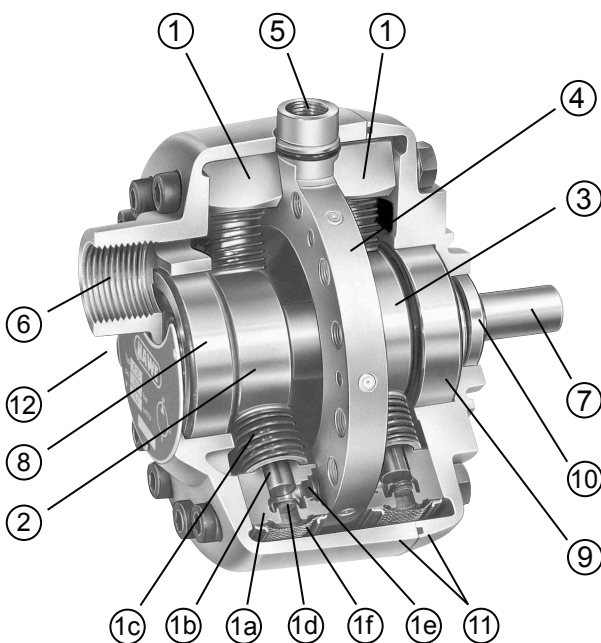

- 1 Pump cylinder, consisting of:
 - 1a Cylinder
 - 1b Piston
 - 1c Return spring for the suction stroke
 - 1d Integrated suction valve
 - 1e Integrated pressure control valve
 - 1f Strainer insert, protects against coarse contamination
- 2 Rear eccentric bearing for the pressure stroke
- 3 Front eccentric bearing for the pressure stroke
- 4 Hydraulic oil manifold
- 5 Hydraulic oil outlet (pressure connection)
- 6 Suction port
- 7 Drive shaft
- 8 Rear shaft bearing
- 9 Front shaft bearing
- 10 Shaft seal
- 11 Housing
- 12 Type plate

2 Available versions, main data

2.1 Order coding

Circuit symbol:

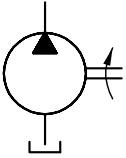

Order coding example:

R	5.8	...	- PYD	- EX	
					Supplement "Table 5"
					Seals "Table 4"
					Versions "Table 3"
					Delivery flow coding "Table 2"
					Basic type "Table 1"

2.2 Pump types and combinations

Table 1 Basic type

Type	Description
R	Series, version with roller bearing
RG	Version with plain bearing (type RG not available for assembly 7631)

Where the load duration is between 75% and 100% in successive work cycles, e.g. accumulator charging mode or similar, the maximum permissible operating pressure should not be fully utilised in order to preserve an economical bearing lifetime. It is better to select a pump with a similar displacement volume and smaller piston diameter.

Table 2 Delivery flow coding

Coding for delivery flow (lpm) at 1450 rpm	Displacement volume V _g (cm ³ /rev)	Operating pressure p _{max} (bar)	Assembly	Pump elements number	Pump element, piston Ø (mm)	Power range of motor (kW)
0.18	0.13	700	7631	2	4	0.25 - 0.55
0.27	0.19	700	7631	3	4	0.25 - 0.75
0.28	0.2	550	7631	2	5	0.25 - 0.55
0.3	0.21	700	6010	1	6	0.25 - 2.2
0.41	0.29	600	6010	1	7	0.25 - 2.2
0.42	0.29	550	7631	3	5	0.25 - 0.75
0.43	0.28	450	7631	2	6	0.25 - 0.55
0.46	0.31	700	7631	5	4	0.25 - 1.1
0.5	0.38	550	6010	1	8	0.25 - 2.2
0.56	0.38	350	7631	2	7	0.25 - 0.55
0.6	0.43	700	6010	2	6	0.25 - 2.2
0.64	0.42	450	7631	3	6	0.25 - 0.75
0.7	0.49	550	7631	5	5	0.25 - 1.1
0.73	0.5	300	7631	2	8	0.25 - 0.55
0.8	0.6	450	6010	1	10	0.25 - 2.2
0.81	0.58	350	7631	3	7	0.25 - 0.75
0.83	0.58	600	6010	2	7	0.25 - 2.2
0.9	0.64	700	6010	3	6	0.25 - 3
0.92	0.64	250	7631	2	9	0.25 - 0.55
1	0.76	550	6010	2	8	0.25 - 2.2
1.08	0.71	450	7631	5	6	0.25 - 1.1
1.1	0.75	300	7631	3	8	0.25 - 0.75
1.2	0.86	350	6010	1	12	0.25 - 2.2
1.25	0.88	600	6010	3	7	0.25 - 3
1.35	0.95	250	7631	3	9	0.25 - 0.75
1.39	0.96	350	7631	5	7	0.25 - 1.1
1.4	1.07	700	6011	5	6	0.25 - 4
1.45	1.01	300	6010	1	13	0.25 - 2.2
1.5	1.15	550	6010	3	8	0.25 - 3
1.6	1.19	450	6010	2	10	0.25 - 2.2
1.7	1.17	250	6010	1	14	0.25 - 2.2
1.77	1.26	300	7631	5	8	0.25 - 1.1
1.9	1.34	200	6010	1	15	0.25 - 2.2
2.08	1.46	600	6011	5	7	0.25 - 4
2.1	1.5	700	6011	7	6	0.55 - 5.5
2.2	1.53	160	6010	1	16	0.25 - 2.2
2.27	1.59	250	7631	5	9	0.25 - 1.1
2.4	1.72	350	6010	2	12	0.25 - 2.2
2.5	1.79	450	6010	3	10	0.25 - 3

Coding for delivery flow (lpm) at 1450 rpm	Displacement volume V _g (cm ³ /rev)	Operating pressure p _{max} (bar)	Assembly	Pump elements number	Pump element, piston Ø (mm)	Power range of motor (kW)
2.6	1.91	550	6011	5	8	0.25 - 4
2.7	2.15	700	6012	10	6	2.2- 7.5 (9)
2.8	2.02	300	6010	2	13	0.25 - 2.2
2.9	2.05	600	6011	7	7	0.55 - 5.5
3.3	2.34	250	6010	2	14	0.25 - 2.2
3.6	2.58	350	6010	3	12	0.25 - 3
3.7	2.67	550	6011	7	8	0.55 - 5.5
3.8	2.69	200	6010	2	15	0.25 - 2.2
4	3.01	700	6012	14	6	2.2 - 11
4.15	2.92	600	6012	10	7	2.2- 7.5 (9)
4.2	2.98	450	6011	5	10	0.25 - 4
4.3	3.03	300	6010	3	13	0.25 - 3
4.4	3.06	160	6010	2	16	0.25 - 2.2
5.1	3.51	250	6010	3	14	0.25 - 3
5.3	3.82	550	6012	10	8	2.2- 7.5 (9)
5.6	4.03	200	6010	3	15	0.25 - 3
5.8	4.18	450	6011	7	10	0.55 - 5.5
5.85	4.09	600	6012	14	7	2.2 - 11
6	4.3	350	6011	5	12	0.25 - 4
6.1	4.3	700	6014	20	6	5.5 - 18.5
6.5	4.58	160	6010	3	16	0.25 - 3
7	5.04	300	6011	5	13	0.25 - 4
7.4	5.35	550	6012	14	8	2.2 - 11
8	6.02	700	6014	28	6	5.5 - 22
8.2	5.97	450	6012	10	10	2.2- 7.5 (9)
8.3	5.85	250	6011	5	14	0.25 - 4
8.35	5.85	600	6014	20	7	5.5 - 18.5
8.4	6.02	350	6011	7	12	0.55 - 5.5
9.5	6.72	200	6011	5	15	0.25 - 4
9.8	7.06	300	6011	7	13	0.55 - 5.5
10.9	7.64	160	6011	5	16	0.25 - 4
11	7.64	550	6014	20	8	5.5 - 18.5
11.6	8.36	450	6012	14	10	2.2 - 11
11.65	8.19	600	6014	28	7	5.5 - 22
11.8	8.19	250	6011	7	14	0.55 - 5.5
12	8.6	350	6012	10	12	2.2- 7.5 (9)
12.7	9.03	700	6016	42	6	11 - 30
13.3	9.4	200	6011	7	15	0.55 - 5.5
14.2	10.09	300	6012	10	13	2.2- 7.5 (9)
15	10.7	550	6014	28	8	5.5 - 22
15.3	10.7	160	6011	7	16	0.55 - 5.5

Coding for delivery flow (lpm) at 1450 rpm	Displacement volume V _g (cm ³ /rev)	Operating pressure p _{max} (bar)	Assembly	Pump elements number	Pump element, piston Ø (mm)	Power range of motor (kW)
16.8	11.7	250	6012	10	14	2.2- 7.5 (9)
17	12.03	350	6012	14	12	2.2 - 11
17.4	11.94	450	6014	20	10	5.5 - 18.5
17.45	12.28	600	6016	42	7	11 - 30
19.3	13.43	200	6012	10	15	2.2- 7.5 (9)
20	14.12	300	6012	14	13	2.2 - 11
21.7	15.28	160	6012	10	16	2.2- 7.5 (9)
22	16.04	550	6016	42	8	11 - 30
23	16.71	450	6014	28	10	5.5 - 22
23.5	16.38	250	6012	14	14	2.2 - 11
25	17.19	350	6014	20	12	5.5 - 18.5
26.5	18.8	200	6012	14	15	2.2 - 11
30	20.18	300	6014	20	13	5.5 - 18.5
30.4	21.39	160	6012	14	16	2.2 - 11
34	24.07	350	6014	28	12	5.5 - 22
34.5	25.07	450	6016	42	10	11 - 30
35	23.4	250	6014	20	14	5.5 - 18.5
38	26.86	200	6014	20	15	5.5 - 18.5
40	28.24	300	6014	28	13	5.5 - 22
43.4	30.56	160	6014	20	16	5.5 - 18.5
47	32.76	250	6014	28	14	5.5 - 22
51	36.1	350	6016	42	12	11 - 30
53	37.6	200	6014	28	15	5.5 - 22
60	42.37	300	6016	42	13	11 - 30
60.8	42.79	160	6014	28	16	5.5 - 22
70	49.14	250	6016	42	14	11 - 30
80	56.41	200	6016	42	15	11 - 30
91.2	64.18	160	6016	42	16	11 - 30

Table 3 Versions

Coding	Description
No designation	Series
A	Mounting type of the shaft seals, e.g. R 3.6 A (see description in Chapter 5.2.2, "Version for slightly charged pumps (above approx. 0.4 ... 0.5 bar)")
H	Hollow shaft version; available for assembly 6010
HFA	Version for water-based fluids, only available for assemblies 6010 to 6016; with piston diameters of 6, 7, 8, 10 or 12. See Chapter 3, "Parameters" "Hydraulic fluids" , preferably with basic type RG

Table 4 Seals

Coding	Description
No designation	NBR series
PYD	FKM seals (VITON)
AT	EPDM seals

Table 5 Supplement

Coding	Description
No designation	Series
EX	Explosion-proof version (other applicable document to be noted: B ATEX)
HC	Hard coat (housing)

2.3 Motor

Power consumption:

$$p_{kW} = \frac{p_{bar} \cdot Q_{lpm} \cdot k}{600 \eta_T} \quad \text{Reference value per customary calculation}$$

where:

p_{kW} = Required drive power at the pump shaft in kW

p_{bar} = Pressure in bar against which the pump should operate
(consumer pressure + flow resistances)

Q_{lpm} = Flow rate in lpm at $1450 \text{ min}^{-1} \approx$ delivery flow coding in [Chapter 2](#);
at different rotation speeds n_x , $Q_{lpm} \approx$ delivery flow coding multiplied by $n_x / 1450$

k = Theoretical factor that takes the pulsation of the pump into account

3 ... 42 cylinders: $k = 1$

2-cylinder pump: $k \approx 1.3 \dots 1.5$

1-cylinder pump: $k \approx 2.7 \dots 3.1$ (highest value where piston diameter is 12 ... 16 mm)

η_T = Overall efficiency of the pump $\approx 0.8 \dots 0.85$

i NOTE

The overall efficiency of the pump may vary depending on the pump element version.

3 Parameters

General information

i NOTE

The following conditions may result in efficiency losses:

- Viscosities > 500 mm²/s and < 10 mm²/s
- Operating pressures < 20 bar
- Rotation speeds > 2000 min⁻¹; especially with a small piston diameter

Designation	Radial piston pump, constant pump				
Installation position	Any angle between horizontal and vertical D 6010 H , section 5				
Attachment	On the front side via the flange				
Line connection	Pipe thread ISO 228-1, for port sizes see dimension drawings Chapter 4, "Dimensions"				
Drive and rotation direction	Via flex-coupling, rotation direction as desired				
Flow direction	Determined by suction and pressure connection, independent of the rotation direction				
Speed range	<p>Continuous:</p> <p>R = 100 ... 2000 min⁻¹ RG = 1000 ... 2000 min⁻¹</p> <p>2800 min⁻¹ admissible for brief periods, please note in this connection that bell housings, flanges, couplings, etc. (D 6010 H) are only available for industrial standard motor sizes 71 to 200 L. The assigned motor power in accordance with DIN 42677 (Table 2) applies to the standard range. If the motor is used under increased speed conditions, a reduction of the maximum pump pressure should be expected, see Chapter 2.3, "Motor".</p>				
Hydraulic fluid	<p>Hydraulic oil: in accordance with (part 1 to 3) 10 ... 68 mm²/s at 40°C; ISO VG 10 to 68 in accordance with DIN ISO 3448</p> <p>Optimum operating viscosity: approx. 10 ... 500 mm²/s</p> <p>Viscosity limits (start viscosity):</p> <table style="width: 100%; border: none;"> <tr> <td style="padding-right: 20px;">Type R 0.18 ... R 2.27:</td> <td>min. approx. 4; max. approx. 800 mm²/s</td> </tr> <tr> <td>R 0.3 ... R 91.2:</td> <td>min. approx. 4; max. approx. 1500 mm²/s</td> </tr> </table> <p>Also suitable for biologically degradable pressure fluids type HEPG (polyalkylene glycol) and HEES (synthetic ester) at operating temperatures up to approx. +70°C. Version type R..-HFA is also suitable for water based pressure fluids. Due to the limited lubricity of the hydraulic fluid, the pump should only be operated in standby mode in order to preserve a reasonable service life. The max. operating pressure should not exceed approx. 75% of the p_{max} indicated in Table 1b.</p>	Type R 0.18 ... R 2.27:	min. approx. 4; max. approx. 800 mm ² /s	R 0.3 ... R 91.2:	min. approx. 4; max. approx. 1500 mm ² /s
Type R 0.18 ... R 2.27:	min. approx. 4; max. approx. 800 mm ² /s				
R 0.3 ... R 91.2:	min. approx. 4; max. approx. 1500 mm ² /s				
Cleanliness level	Recommended cleanliness in accordance with ISO 4406, see oil recommendation D 5488/1				
Temperatures	<p>Ambient temperature: approx. -40 ... +80°C, Oil temperature: -25 ... +80°C, pay attention to the viscosity range. Start temperature: down to -40°C is permissible (observe start viscosities!), as long as the steady-state temperature is at least 20K higher during subsequent operation. Biologically degradable hydraulic fluids: note manufacturer specifications. With consideration for the seal compatibility, not above +70°C.</p>				

Pressure and flow rate

Operating pressure	<p>Pressure side (outlet): Depending on piston diameter, see Chapter 2, "Available versions, main data"</p> <p>Suction side: - 0.3 bar ... + 1 bar (approx. 0.7 bar abs. ... approx. 2 bar abs.) + 2 bar (3 bar abs.) with type R(G) ... - A, see Chapter 5.2.2, "Version for slightly charged pumps (above approx. 0.4 ... 0.5 bar)"</p>						
Flow rate	<p>See "Table 2"</p> <p>Reference value depending on rotation speed:</p> $Q_{PU} = V_g n \cdot \eta_{Vol} \cdot 10^{-3} \text{ lpm}$ <p>where:</p> <table data-bbox="560 739 1498 884"> <tr> <td>V_g in cm^3/rev</td> <td>Geometric displacement "Table 2"</td> </tr> <tr> <td>n in min^{-1}</td> <td>Rotation speed</td> </tr> <tr> <td>$\eta_{Vol} \approx 0.98$</td> <td>Volumetric efficiency</td> </tr> </table>	V_g in cm^3/rev	Geometric displacement "Table 2"	n in min^{-1}	Rotation speed	$\eta_{Vol} \approx 0.98$	Volumetric efficiency
V_g in cm^3/rev	Geometric displacement "Table 2"						
n in min^{-1}	Rotation speed						
$\eta_{Vol} \approx 0.98$	Volumetric efficiency						

Weight

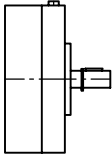
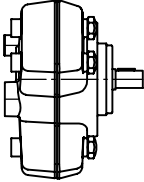
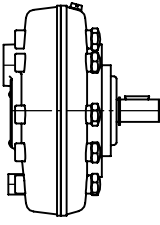
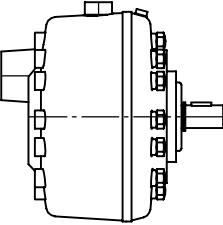
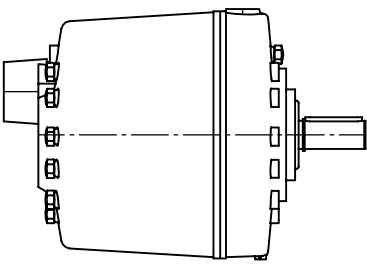
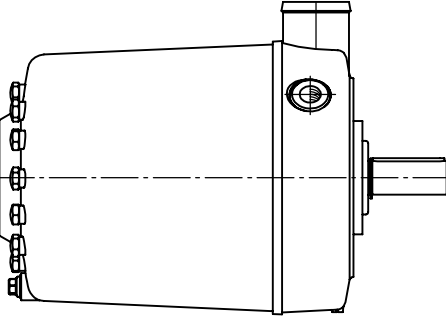
7631	Assembly	Number of cylinders	m (kg)
		2	3.0
		3	3.1
		5	3.2
6010		1	2.5
		2	2.5
		3	3.1
6011		5	5.0
		7	5.8
6012		10	8.7
		14	10.5
6014		20	21.5
		28	24.2
6016		42	39.1

Characteristics

The specified noise level ranges include the results obtained from practical measurements in a test workroom with the identifiable scattering. Pumps with small flow rates (smaller piston diameters) within an assembly usually tend to be in the lower range, pumps with larger flow rates (13 to 16 mm piston diameters) are usually closer to the middle to upper range.

Running noise

Oil viscosity approx. 50 mm²/s

Measuring conditions: Quiet workroom with noise level at approx. 37 dB (A); measured 1 m above the ground and 1 m away from the object

Measurement device: Precision noise level measurement device DIN IEC 651 Kl.I

Assembly 7631

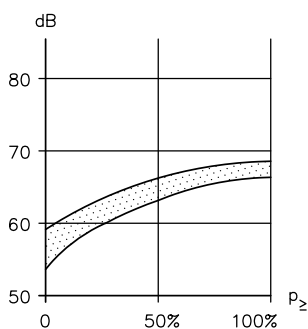

Assembly 6010

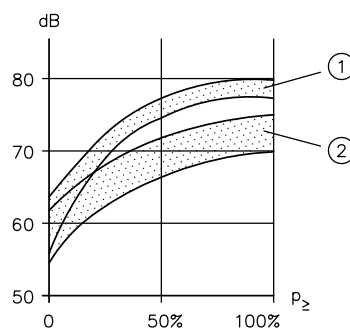

- 1 1-cylinder pump
- 2 2-cylinder pump

Assembly 6011

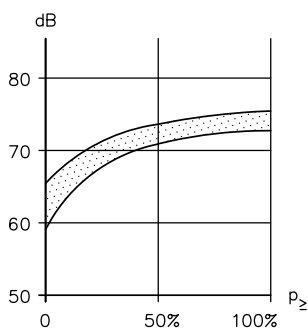

Assembly 6012

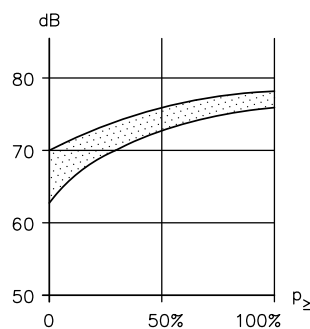

Assembly 6014

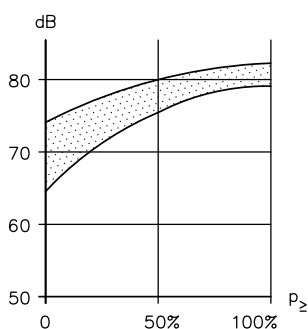

Assembly 6016

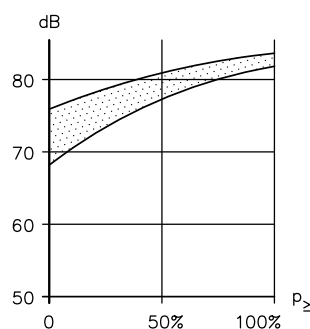

p_{max} pressure ratio; dB noise level (A)

4 Dimensions

All dimensions in mm, subject to change.

4.1 Assembly 7631

2, 3, and 5-cylinder pump

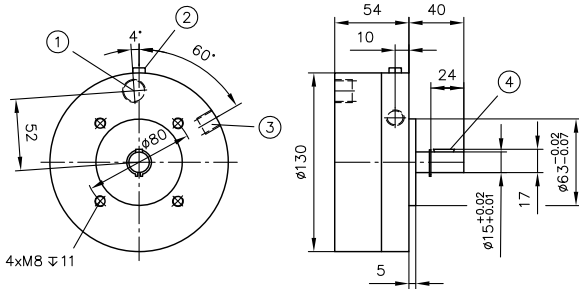

- 1 Suction port G 3/8 (BSPP)
- 2 Venting
- 3 Pressure connection P G 1/4 (BSPP)
- 4 Wedge width 5

4.2 Assembly 6010

1 and 2-cylinder pump

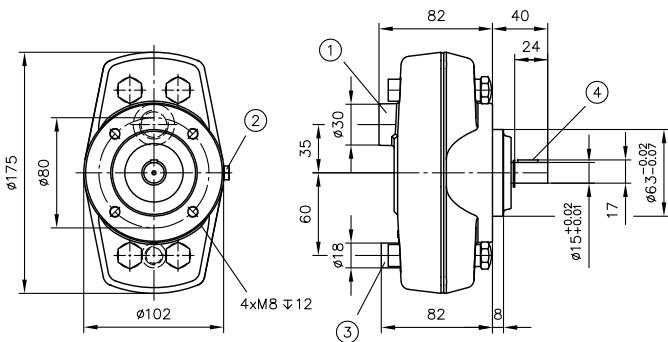

- 1 Suction port G 1/2 (BSPP)
- 2 Venting
- 3 Pressure connection P G 1/4 (BSPP)
- 4 Wedge width 5

3-cylinder pump

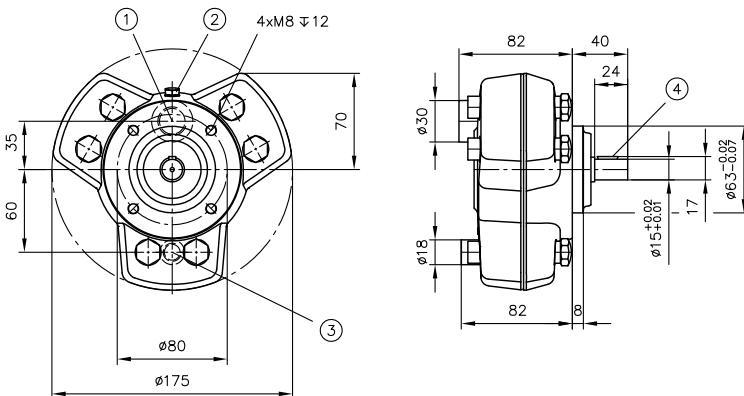

- 1 Suction port G 1/2 (BSPP)
- 2 Venting
- 3 Pressure connection P G 1/4 (BSPP)
- 4 Wedge width 5

Assembly 6010, 2(3)-cylinder pump

Coding H

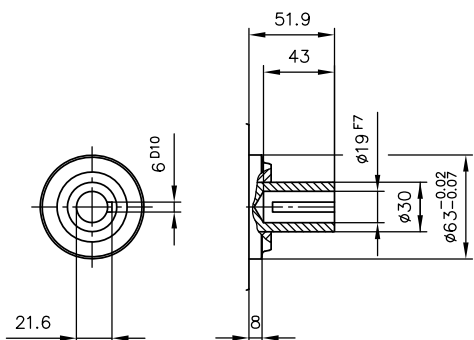

4.3 Assembly 6011

1-radial pump

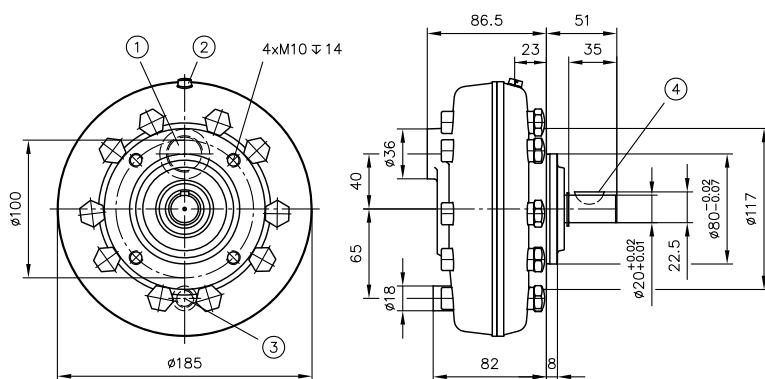

- 1 Suction port G 3/4 (BSPP)
- 2 Venting
- 3 Pressure connection P G 1/4 (BSPP)
- 4 Wedge width 6

4.4 Assembly 6012

2-radial pump

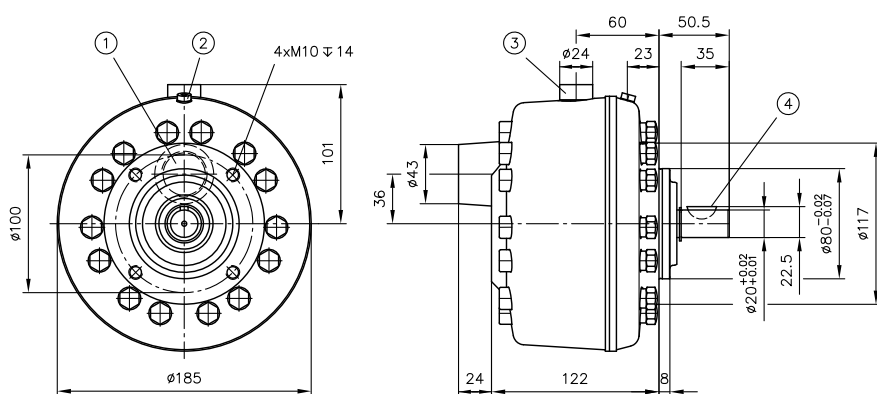

- 1 Suction port G 1 (BSPP)
- 2 Venting
- 3 Pressure connection P G 3/8 (BSPP)
- 4 Wedge width 6

4.5 Assembly 6014

4-radial pump

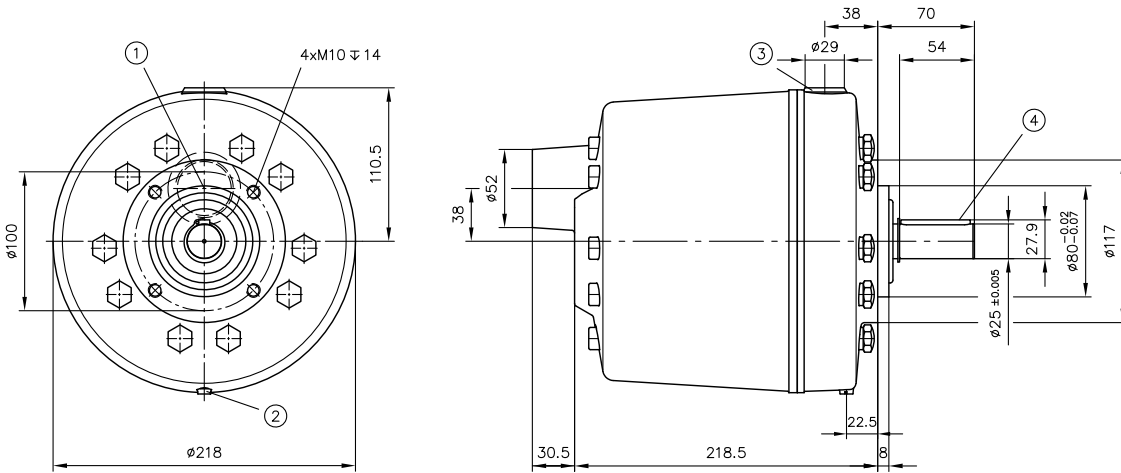

- 1 Suction port G 1 1/4
- 2 Venting
- 3 Pressure connection P G 1/2
- 4 Wedge width 8

4.6 Assembly 6016

6-radial pump

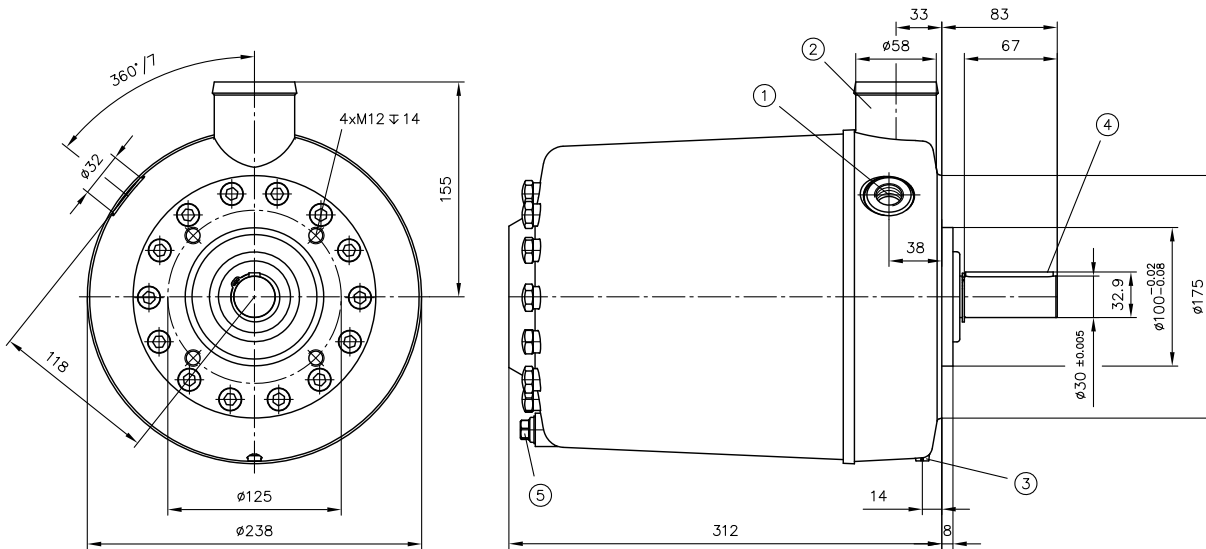

- 1 Pressure connection P
G 1/2 for R 12.7 to R 22.0
G 3/4 for R 34.5 to R 91.2
- 2 Suction port G 1 1/2 (BSPP)
- 3 Venting
- 4 Wedge width 8
- 5 Oil drain screw G 1/4

5 Installation, operating, and disposal instructions

5.1 Intended use

This pump is exclusively intended for hydraulic applications (fluid engineering).

The user must observe the safety measures and warnings in this documentation.

Essential requirements for the product to function correctly and safely:

- All information in this documentation must be observed. This applies in particular to all safety measures and warnings.
- The product must only be assembled and put into operation by qualified personnel.
- The product must only be operated within the specified technical parameters. The technical parameters are described in detail in this documentation.
- All components must be suitable for the operating conditions in the event of application in an assembly.
- The operating and maintenance manual of the components, assemblies and the specific complete system must also always be observed.

If the product can no longer be operated safely:

1. Remove the product from operation and mark it accordingly.
- ✓ It is then not permitted to continue using or operating the product.

5.2 Assembly information

The product must only be installed in the complete system with standard and compliant connection components (screw fittings, hoses, pipes, fixtures etc.).

The product must be shut down correctly prior to dismantling (in particular in combination with hydraulic accumulators).

When both setting up the component as a motor pump outside an oil tank and installing it in an oil tank as a hydraulic power pack, care must be taken to ensure that the pump remains below the oil level at all times, even when the oil has been pre-filled before use. The housing shell forms a sealed space around the pump cylinders, which are arranged in a star configuration. This space can only be vented effectively when the pump is submerged as described during or after filling. For details on installation, venting and commissioning, see [D 6010 H](#), Section 5.



DANGER

Risk to life caused by sudden movement of the hydraulic drives when dismantled incorrectly!

Risk of serious injury or death.

- Depressurise the hydraulic system.
- Perform safety measures in preparation for maintenance.

5.2.1 Venting and commissioning

When commissioning the pump for the first time and after each oil change, bleed the pumps to prevent problems with the suction and air from entering the loads. See operating and maintenance manual [B 6010](#).

5.2.2 Version for slightly charged pumps (above approx. 0.4 ... 0.5 bar)

Series:
Sealing lips facing each other - no marking

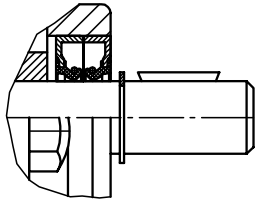

Version R ... A:
Sealing lips facing inwards for suction pressures exceeding approx. 0.4 bar

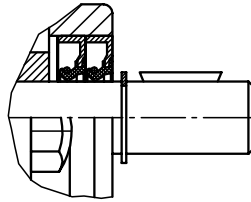

The drive shaft is sealed to the outside on the shaft journal by two radial sealing rings arranged one behind the other. The sealing lips are installed as standard so that they face each other. This ensures that, when the pump is operating, no air can penetrate during suction (negative pressure in the pump housing) and no oil can escape outside even if the pump is located underneath the oil tank (slight overpressure in the pump housing due to the weight of the oil column).

For applications where the oil tank is installed much higher than the pump (e.g. several meters) or a closed oil tank is kept (charged) under constant low overpressure $p_s > 0.4$ bar, the pumps can also be supplied with both sealing lips facing inwards.

However, it should be noted that charging pressures above 1 bar (2 ... 3 bar still permissible) can greatly reduce the lifetime of the sealing lips and can only be tolerated in systems with low switching frequency, i.e. long downtimes.

5.3 Operating instructions

Note product configuration and pressure / flow rate

The statements and technical parameters in this documentation must be strictly observed.
The instructions for the complete technical system must also always be followed.

i NOTE

- Read the documentation carefully before usage.
- The documentation must be accessible to the operating and maintenance staff at all times.
- Keep documentation up to date after every addition or update.

Purity and filtering of the hydraulic fluid

Fine contamination can significantly impair the function of the hydraulic component. Contamination can cause irreparable damage.

Examples of fine contamination include:

- Metal chips
- Rubber particles from hoses and seals
- Dirt due to assembly and maintenance
- Mechanical debris
- Chemical ageing of the hydraulic fluid

i NOTE

New hydraulic fluid from the manufacturer does not necessarily have the required level of purity.
The hydraulic fluid must be filtered during filling.

In order to maintain faultless operation, ensure that the cleanliness level of the hydraulic fluid is correct.
(See Cleanliness level in [Chapter 3, "Parameters"](#))

Additionally applicable document: [D 5488/1](#) Oil recommendations

5.4 Disposal information

- Valve control
 - mixed scrap
- Pump housing with motor
 - electronic waste
- Tank or hydraulic accumulator, as applicable (depressurised on the gas side)
 - scrap iron
- Hydraulic fluid
 - waste oil

6 Other information

6.1 Accessories, spare parts and separate components

- Spare parts (pump elements) [D 5600](#)

Further information

Additional versions

- Motor pump and hydraulic power pack type R and RG: D 6010 H
- Radial piston pump type R and RG with several pressure connections: D 6010 D
- Hydraulic power pack type R and RG: D 6010 DB
- Radial piston pump type R and RG with one main pressure connection and one or two ancillary pressure connections: D 6010 S

Further information

HAWE Hydraulik SE is a responsible development partner with application expertise and experience in more than 70 areas of mechanical engineering and plant engineering. The product range includes hydraulic power packs, constant and variable pumps, valves, sensors and accessories. The modular system is complemented by electronic components that are perfectly coordinated with the hydraulic components and that simplify control, signal evaluation and fault detection. The intelligent system solutions reduce energy consumption and operating costs. Compact drives save space and permit innovative machine design.

Across the globe, approximately 2000 employees in 16 countries and sales partners in more than 40 countries provide customers with local, professional and personal support.

The company is certified in accordance with ISO 9001, ISO 4413, ISO 50001, OHSAS 18001.



■ HAWE subsidiaries and service repair shops

- Germany
- Finland
- France
- Italy
- Austria
- Switzerland

● HAWE sales partners

- Slovenia
- Spain
- Sweden
- USA
- Canada
- Russia
- China
- India
- Japan
- Korea
- Singapore
- Australia

You can find further information on HAWE Hydraulik, your local contact and the range of hydraulics training sessions offered at: www.hawe.com.