

Compact hydraulic power pack type HK 3..

Type HK 34 nominal power 1.1 kW

Type HK 33 nominal power 0.8 kW

Fan cooled, for continuous and intermittent service; single circuit pump



For higher power demand see HK 4..., HKF 4... D 7600-4
 For lower power demand (only single circuit pumps) see HK 24 D 7600-2

Delivery flows: 0.9 ... 6.5 l/min
 Operating pressure: 700 ... 45 bar

1. General description and information

Terminal box with cable gland M20x1.5. Six pin terminal strip enables the customer to connect either in Y-mode (standard) for 3 x 400V 50 Hz or Δ-mode for 3 x 230V 50 Hz. Additional terminal strip for optional float switch or temperature switch.

Two different designs are available for the filler neck; There is also a screen filter 0.4 x 0.22 installed in the bearing housing.

Filling gauge with Max./min. - marking

Bottom housing section with radial piston pump for pressure ranges up to 700 bar or play compensated gear pump for pressure ranges up to 170 bar and stator (shrunk in) as well as armature of the drive motor. Drive motor lay-out for 3~400/230V 50 Hz YΔ (IEC 38) as standard, nominal power 1.1 or 0.8 kW. Further nom. voltages possible e.g. for 500V 50 Hz, 220V 60 Hz.

Main connection pedestal with one pressurized oil outlet and reflow inlet port. Prepared for the mounting of connection blocks for ongoing pressure and reflow pipes or with directly mounted directional valve banks (illustrated).

Top cover (bearing carrier) with upper bearing of the shaft, oil filler neck (see fluid fill-up) breather, leads connection stator winding → terminal enclosure (see there). Fan shroud with largely dimensioned fan wheel. The complete upper section is also available rotated by 3x90° in relation to the bottom section. The fan shroud directs the stream of air, which is created by the fan wheel, through the ribs and thereby ensures an intensive heat dissipation to the surroundings. These compact hydraulic power packs are therefore suitable for the VDE 0530 operating modes S1 (continuous operation) in the range of the nominal power as well as S6 (permanent running with idle sequences). Thereby approx. up to 1.8 of the nom. power rating can be employed. S3 (intermittent service) is also possible. The cooling effect of the large finned surface is also very good at standstill of the motor.

Finned tubular tank with fluid level gauge (Plexiglas tube) and alternatively with temperature switch. It is connected via a press fit with the bottom housing where the stator shrunk in. This helps to conduct the generated heat from the armature to the cooling fins.

Second or auxiliary pedestal with optional reflow port.

The pump section is easily accessible from the underside after removing the bottom cover, e.g. for maintenance.

1.1



HAWE HYDRAULIK GMBH & CO. KG
 STREITFELDSTR. 25 • 81673 MÜNCHEN

D 7600-3
 Compact-hydraulic power pack HK 3..

2. Type coding compact hydraulic power pack type HK 3..

Order example:

HK 34 8 LST /1 M - H3,6 - A1/200 3~230/400V 50 Hz

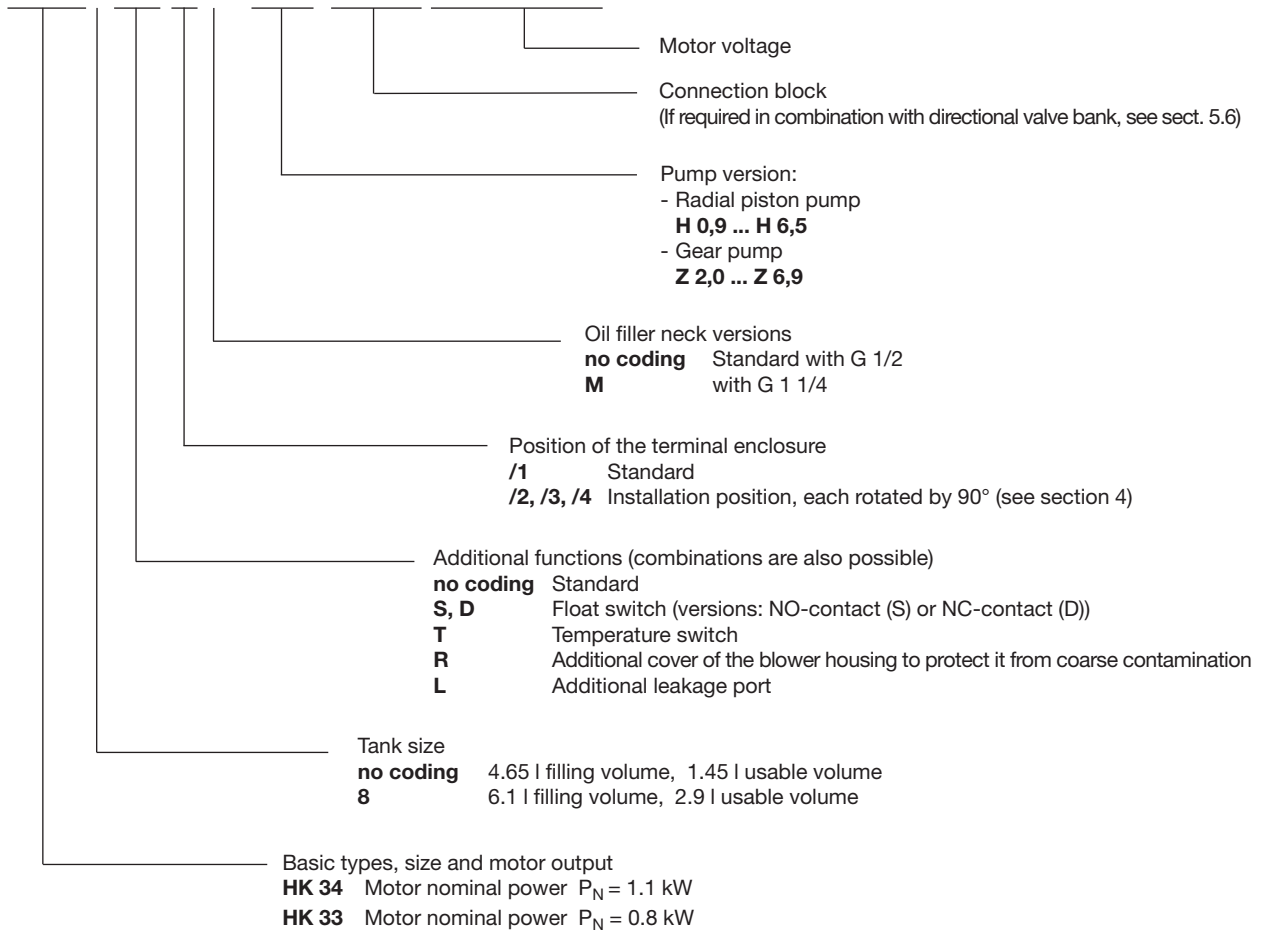

For further order examples, optional connection blocks and valve banks, see sect. 5.6.

HK 34/1 - H1,25 - A3/500 - VB01FM - R3 N3 R3 N3 - 32 - G24

Additional spec.:
Motor voltage
3~230/400V 50 Hz

HK 338/1M - Z4,5 - SWC1/100 - UGG - 1 - G24

Additional spec.:
Motor voltage
3~230/400V 50 Hz

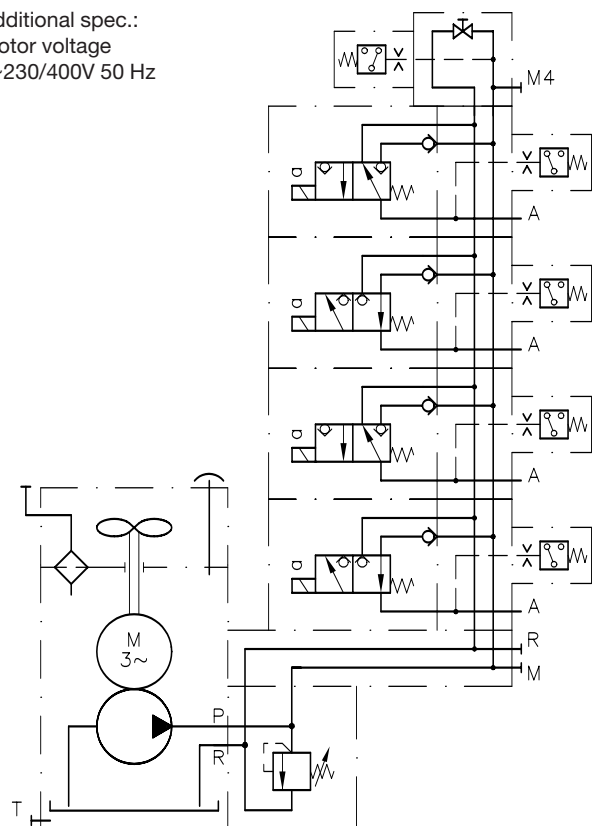
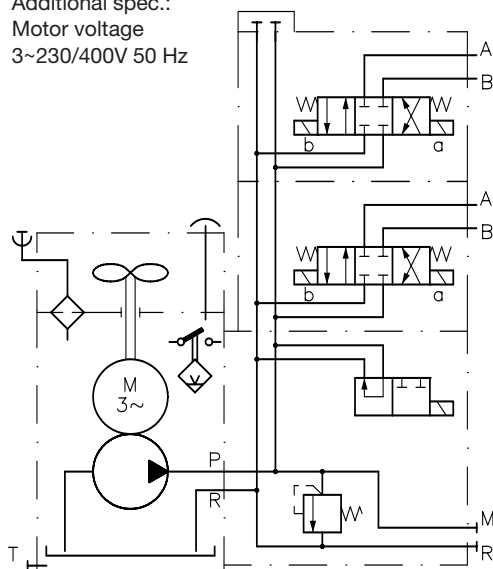



2.1 Motor and tank section

Both, plus the pump section (see section 2.2) yield the basic hydraulic power pack.

Order example 1: **HK 338 L ST/1M - Z3,5 - AL21 F2 - E50/60** 3~230/400V 50 Hz
Motor voltage

Order example 2: **HK 34/1 - H0,9 - A2/600** 3~230/400V 50 Hz
Motor voltage

Table 1: Versions for motor and tank

	Codings	Filling volumes approx. (l)	Usable filling volume approx. (l)	Motor nominal power	
				400V ∇ 230V Δ 50 Hz (kW)	460V ∇ 265V Δ 60 Hz (kW)
Basic type and size	HK 34	4.65	1.45	1.1	1.3
	HK 348	6.1	2.9		
	HK 33	4.65	1.45	0.8	1.0
	HK 338	6.1	2.9		
Additional leakage reflow port G 3/4		L	For high and hot leakage reflow (due to operation), e.g. from chucks of lathes. The leakage reflow is led in such a way that the carried along dissipated heat is drawn off by the fan cooling.		
Optional equipment acc. to section 4.3	Without switch	Without coding		Standard version	
	Float switch	S	NO-contact		
		D	NC-contact		
	Temperature switch	T	NC-contact		
	Float and temperature switch	ST or DT	For circuitry see section 3.3		
Additional cover of the blower housing to protect it from coarse contamination	R				
Top part with breather, terminal enclosure etc., see section 4	Standard			/1	See dimensional drawing in sect. 4
	Rotated anti-clockwise			/2	90°
				/3	180°
				/4	270°
Oil filler neck	Standard with filler hole G 1/2			no coding	
	With filler reducer G 1 1/4			M	

Symbols

acc. to example 1

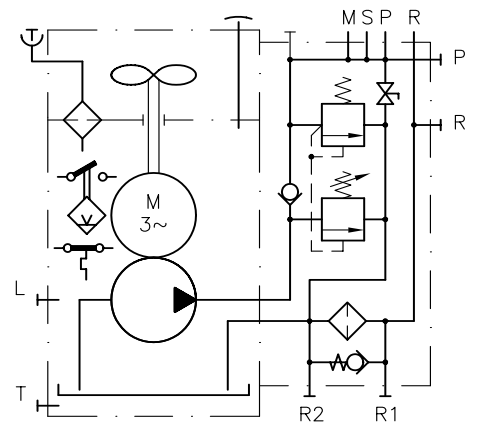

acc. to example 2

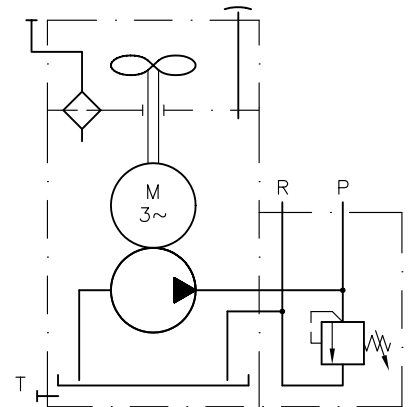

2.2 Pump section

The pressurized oil outlet is always led to the main connection pedestal.

Order example: HK 34/1 - **H5,1** - C5 3~230/400V 50 Hz
Motor voltage

HK 33/1 - **Z2,7** - A1/120 3~230/400V 50 Hz
Motor voltage

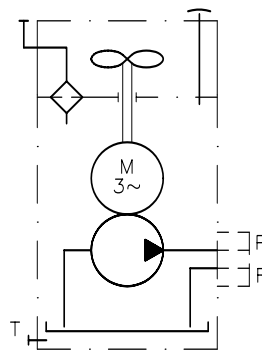

Symbol for the basic hydraulic power pack valid only for pumps acc. to table 2a and 2b

Table 2a: High pressure radial piston pump with a delivery flow (flow corresponds to 3 pump cylinders)

H	Codings for radial piston pump (high pressure pump)	Piston diameters (mm)									
		6	7	8	10	12	13	14	15	16	
	Delivery flow coding	0,9	1,25	1,5	2,5	3,6	4,3	5,1	5,6	6,5	
	Geom. displacement V_g (cm ³ /U)	0.64	0.88	1.15	1.79	2.58	3.03	3.51	4.03	4.58	
	Delivery flow $Q_{Pu}^{1)}$ (l/min)	50 Hz	0.88	1.21	1.56	2.45	3.54	4.1	4.8	5.5	6.3
		60 Hz	1.06	1.45	1.87	2.94	4.25	4.9	5.76	6.6	7.56
Permissible pressure	HK 34	p_1 (bar)	700	530	420	260	180	150	130	110	100
		p_{max} (bar)	700	700	700	440	310	260	220	200	170
	HK 33	p_1 (bar)	530	380	290	180	130	110	90	80	70
		p_{max} (bar)	700	560	430	270	190	160	140	125	100

Continuous operation S1 ^{2) 3)}
No-load/load operation S6-10 min with approx. 30% LD

Table 2b: Gear pump for low and mid range pressure applications. Delivery flow dependson the size.

Z	Codings for gear pump	20	27	35	45	52	69	
	Delivery flow codings	20	27	35	45	52	69	
	Geom. displacement V_g (cm ³ /U)	1.4	1.9	2.4	3.1	3.6	4.8	
	Delivery flow $Q_{Pu}^{1)}$ (l/min)	50 Hz	1.9	2.6	3.3	4.2	5	6.6
		60 Hz	2.28	3.12	3.96	5.04	6	7.92
Permissible pressure	HK 34	p_1 (bar)	170	170	170	150	130	90
		p_{max} (bar)	170	170	170	170	170	160
	HK 33	p_1 (bar)	170	170	140	100	90	70
		p_{max} (bar)	170	170	170	160	130	100

Continuous operation S1 ⁴⁾
No-load/load operation S6-10 min with approx. 30% LD ⁴⁾

¹⁾ Reference value referring to a nominal speed of 1395 rpm with mains frequency 50 Hz or 1750 rpm with mains frequency 60 Hz. Delivery flow reduction due to speed drop of the motor in the range of p_{max} , see also sect. 5.1. The delivery flow coding can be regarded as a rough reference value for the flow at mains frequency 50 Hz.

²⁾ An inertia excess temperature of approx. 50K can be expect with the max. permissible pressure mentioned in the tables 2a and 2b, if p_1 is not exceeded in continuous operation S1 and the indicated load periods are apparent in the no-load/load operation S6-10 min. This temperature usually will be considerably lower in the practical case, see also section 5.3. These temperature figures do apply to usual operation, taking into consideration the unavoidable losses due to back pressure in pipes and valves. Additional losses caused by flow control valves, pressure control valves, orifices etc. may lead to a higher inertia excess temperature, depending on the time involved.

³⁾ The middled pressure of subsequent load cycles (e.g. at accumulator charging operation) should not exceed 50... 60% of p_1 to ensure an economic service life of the bearings.

⁴⁾ Max. pressure depending on the displacement. The continuous pressure requirement should be below 100 bar, to ensure an economic service life of the gear pump.

3. Further characteristic data

3.1 General information

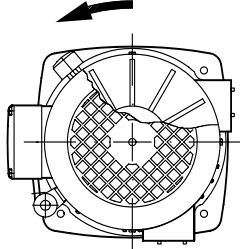
Nomenclature	Constant delivery pump		
Design	Valve controlled radial piston pump or play compensated gear pump (with external toothing)		
Direction of rotation	Arbitrary for radial piston pumps (version H..), delivery flow direction remains the same.		
	<p>Versions with gear pumps (coding Z...) must rotate anti clockwise always. It is therefore necessary to check the rotation direction of the motor. The fan wheel has to rotate anti clockwise after starting the motor when looking through the perforation of the fan shroud. The connection of two of the three main wires has to be interchanged at the terminal strip or the special plug CEE 17 (DIN 49462) should be used enabling these changes in the plug, if the direction of rotation is wrong.</p>		
			
Mass (weight)	HK 34(33)..../..	- H(Z)	= 20.5 kg
	HK 348(338)..../..	- H(Z)	= 22.2 kg
Installed position	Only vertically standing		
Fastening	Four bore holes Ø9 on the bottom side, see also section 4		
Pipe connection	Depending on the connection block, see section 5.6		
	P	Pressurized oil outlet	
	R	Reflow port (must not be used as suction port)	
	T	Connectivity for an auxiliary tank to increase the usable filling volume, G 3/4. Attention: Reflow pipe must not be connected!	
	A, B ..	Consumer ports if directional valve banks are mounted, see also the pamphlets mentioned in section 5.6, G 1/4 or G 3/8	
	L	Leakage port G 3/4 (must not be used as suction port)	
Ambient temperature	-40 ... +60°C		
Filling and usable volumes	Do not exceed the max. fluid levels (see marking), because the remaining volume is required when the fluid temperature rises.		

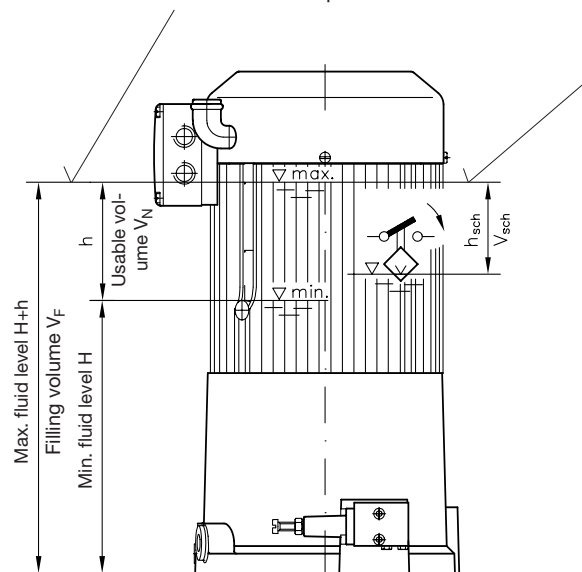

Versions with float switch (section 3.3) provide a signal, as soon as the fluid level drops by h_{Sch} below the max. level and the volume V_{Sch} is removed.

Dimensions and volumes are approx. figures	HK 34 HK 33	HK 348 HK 338
Fluid level min. H (mm)	230	230
Perm. level drop h (mm)	88	178
Filling volume V_F (l)	4.65	6.1
Total usable filling volume V_N (l)	1.45	2.9
Fluid level drop h_{Sch} (mm)	55	152
Removed volume V_{Sch} (l)	0.9	2.5

The specific usable filling volume is 0.165 l per 10 mm of fluid level drop. The motor outline (winding overhang) is no longer oil immersed if the fluid level drops below the min. marking. Any further drop will result in no considerable volume gain as the bottom interior is occupied by functional parts.

3.2 Hydraulic data

Pressure range	Delivery side (outlet ports P..) depending on pump design and delivery flow, see sect. 2.2 ++.
Pressure fluid	Hydraulic oil conforming DIN 51514 part 1 to 3: ISO VG 10 to 68 conform. DIN 51519. Viscosity range: Viscosity during start min. approx. 4; max. approx. 1500 mm ² /s opt. service: approx. 10 ... 500 mm ² /s Also suitable are biologically degradable pressure fluids type HEES (Synth. Ester) at service temperatures up to approx. +70 °C. Electrically hazardous: Any fluid types containing water must not be used (short-cut).
Temperature	Ambient: approx. -40 ... +60 °C Fluid: -25 ... +80°C, Note the viscosity range ! Permissible temperature during start: -40°C (observe start-viscosity!), as long as the service temperature is at least 20K higher for the following operation. Biologically degradable pressure fluids: Observe manufacturer's specifications. By consideration of the compatibility with seal material not over +70 °C.

3.3 Electrical data

Type of pump		HK 34 and HK 348		HK 33 and HK 338	
Motor		For 3-phase mains, 4-poles, stator shrunk into the pump housing			
Nom. voltage ¹⁾	(V)	400/230 YΔ	460/265 YΔ	400/230 YΔ	460/265 YΔ
Mains frequency	(Hz)	50	60	50	60
Rev. rating	(min ⁻¹)	1410	1720	1340	1610
Output	(kW)	1.1	1.3	0.8	1.3
Current	(A)	2.7 / 4.7	2.4 / 4.2	2.0 / 3.5	1.7 / 2.9
Start current ratio	(I _A /I _N)	5.4	5.0	4.2	4.0
Power factor	(cos φ)	0.81	0.8	0.91	0.9
Protection classification		IP54	IP54	IP54	IP54

¹⁾ For permissible voltage ranges see section 5.1

Terminals, if optional equipment is apparent

Terminal box at the pump housing

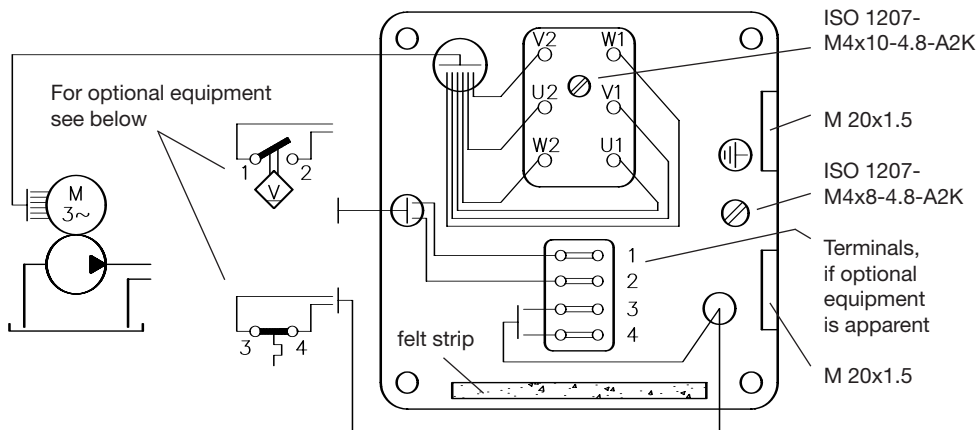

Customer furnished circuitry

Mains 3 ~ 400V
Y-connection
(state of delivery)

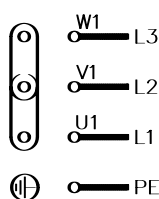

Mains 3 ~ 230V
Δ-circuitry

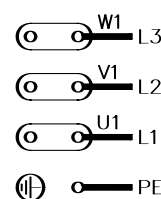

Optional equipment

Float switch:

Signaling takes place, if approx. 1.0 l is removed.
 Max. switched power DC/AC 60 W / 60 VA
 Permissible current DC and AC 0.8 A (cos φ = 1)
 Max. voltage 230V 50 and 60 Hz
 Temperature range approx. -10 ... +80°C
 A protective circuit should be employed with inductive load.

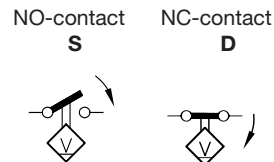

Temperature switch:

A signal is triggered above a housing temperature of approx. 85°C.
 Max. voltage 250V 50 and 60 Hz
 Nom. current (cos φ ~ 0.6) 1.6 A
 Max. voltage with 6 ... 24V DC 1.5 A (cos φ = 1)

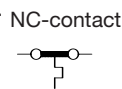

Electr. connection:

HK 34 S or HK 34 D
 The float switch S or D is always connected to 1-2

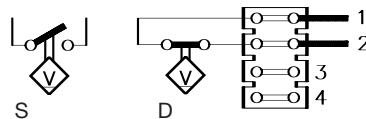

HK 34 T
 The temperature switch T is always connected to 3-4

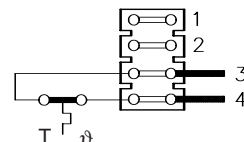

HK 34 DT
 Both switches D and T are connected in series via bridge 2-3 ex-works and shall be attached by 1-4. This bridge is to be removed if they should be used individually.

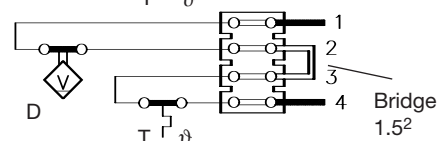

Attention:

The temperature switch may also be retrofitted. The float switch can't be retrofitted (only available ex-works).

HK 34 ST
 The float switch S is connected to 1-2
 The temperature switch T is connected to 3-4

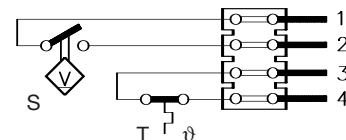

4. Unit dimensions

All dimensions are in mm and are subject to change without notice!

For the dimensions of the different connection blocks see the corresponding pamphlets listed in sect. 5.6

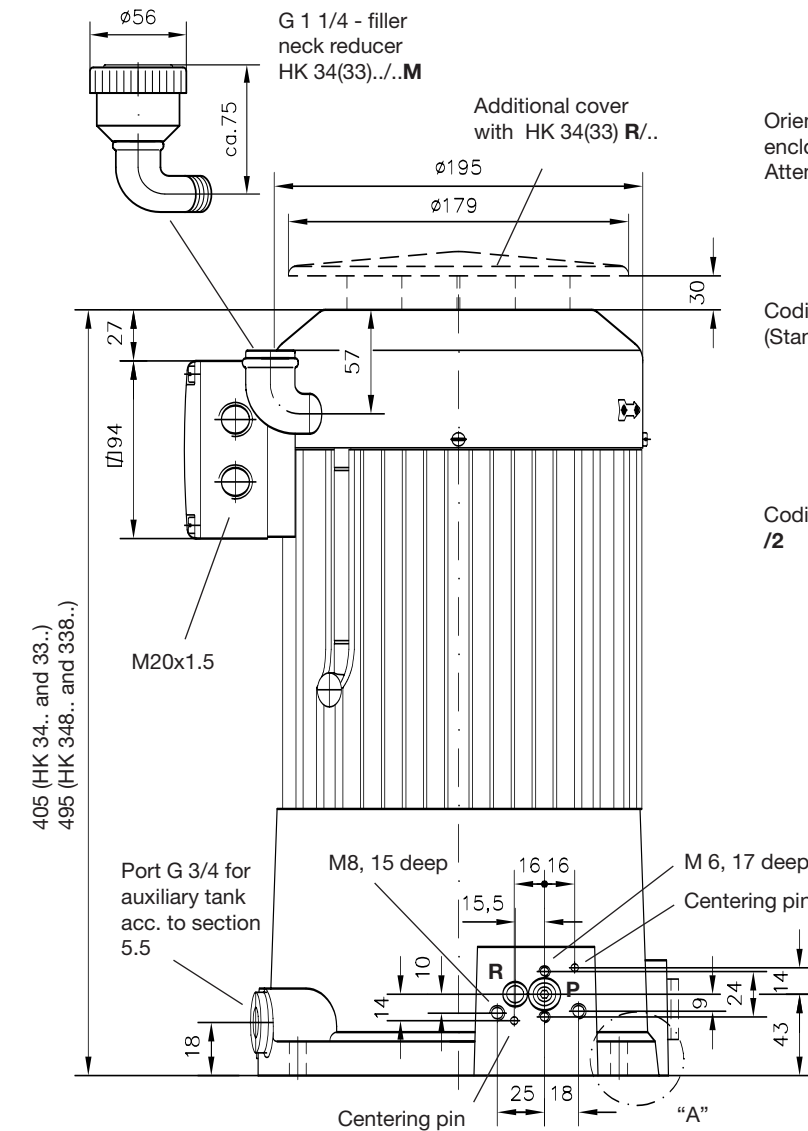

Orientation of the upper part of the pump with terminal enclosure
 Attention: The 4 terminal box positions include the complete upper part (finned tube) and the oil level gauge.

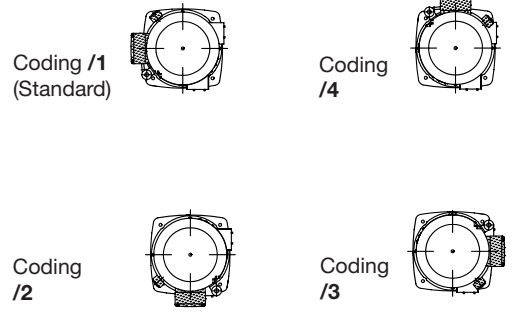

Detail A:

Installation example

M 8 x 25
 Silentbloc $\phi 40 \times 30$ / M8 (65 Sh), also see sect. 5.4

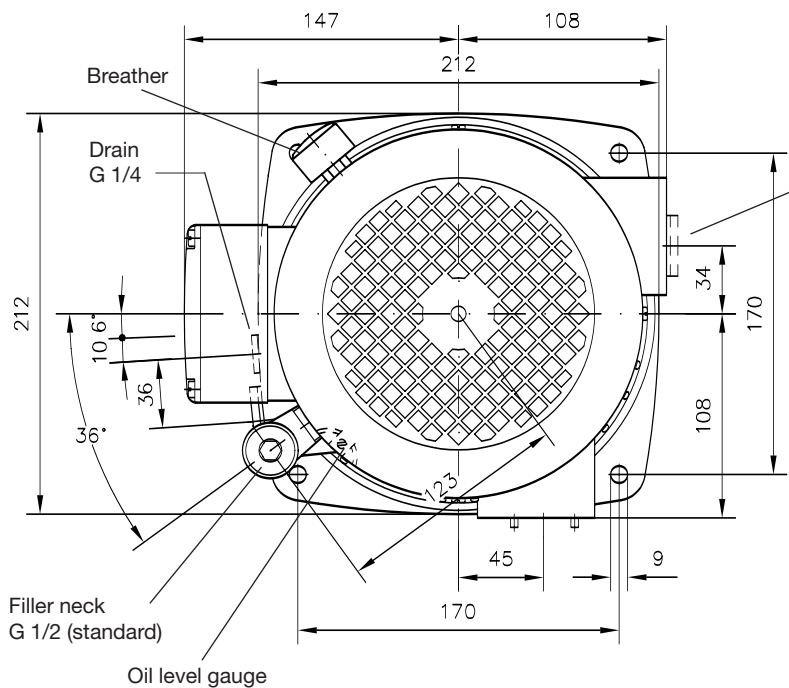
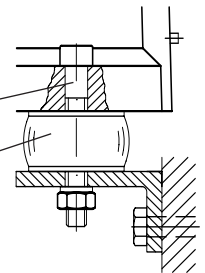

Version HK 3..L:

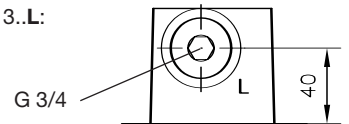

O-Rings:
 10x2 NBR 90 Sh
 8x2 NBR 90 Sh

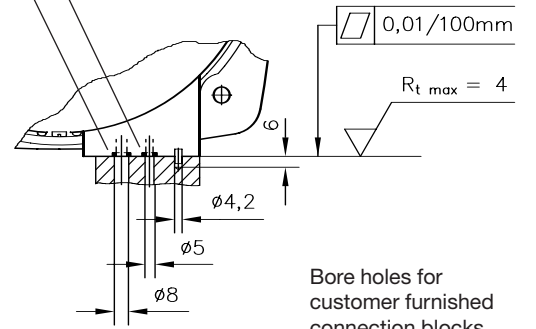

5. Appendix

5.1 I_M - p_B - Q_{pu} - characteristics

The current consumption of the motor depends strongly on its load. The nominal figures of sect. 3.3 apply strictly to one operating point only. The pumps may be operated continuously up to the max. pressure p₁ stated in sect. 2.2. Up to 1.8s of the nominal power of the motor can be exploited during load / no load operation. The increased heat built-up under these conditions gets intensively radiated during the idle periods (also see sect. 5.3).

HK 34..

Operating voltage 400/230V 50 Hz YΔ

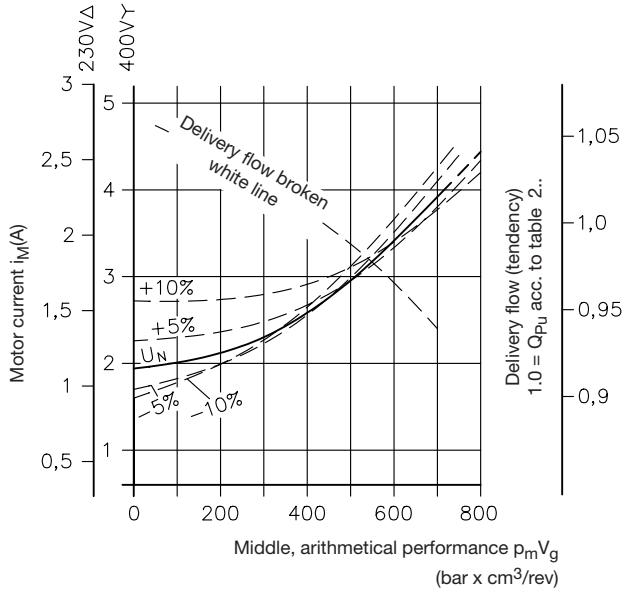

HK 34..

Operating voltage 460/265V 60 Hz YΔ

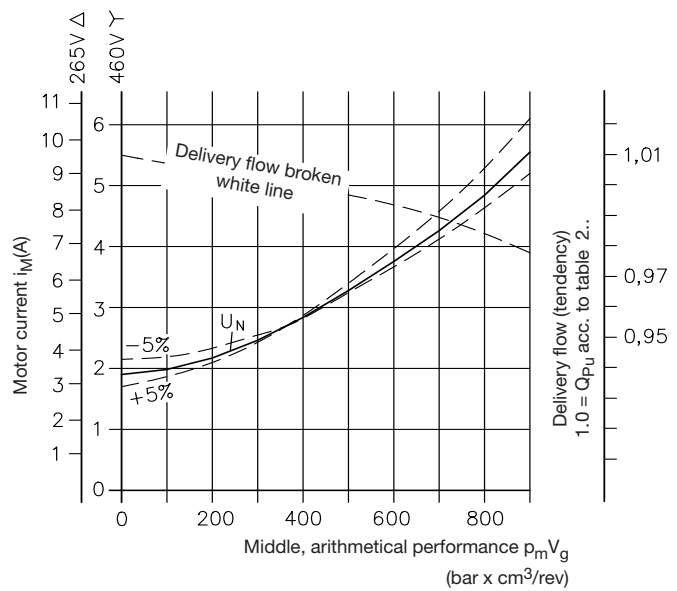

HK 33..

Operating voltage 400/230V 50 Hz YΔ

Operating voltage 460/265V 60 Hz YΔ

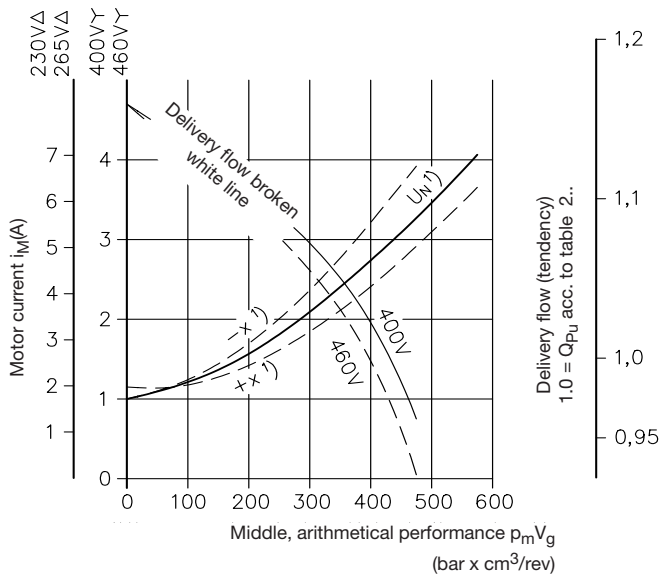

The product of pV_g (bar · cm³/rev) is laid off as abscissa in these curves. This makes a rough consideration possible for the current and the delivery flow to be expected, which is sufficient under most conditions.

p_m = Middle operating pressure (bar)

V_g = Geometric displacement (cm³)
(according to flow codings)

1) U_N = 400/230V 50Hz
460/265V 60Hz

x	U, f
-10%	360/210V 50Hz
-5%	440/250V 60Hz
+10%	440/250V 50Hz
+5%	480/280V 60Hz

Permissible voltage ranges

Mains: 50 Hz ±10% UN (like IEC 38)

Mains: 60 Hz ±5% UN

Reduced voltage will cause a performance drop (Δ reduced p_{max}).

Reference value: p_{oper.} ≈ 0.85 p_{max.} · $\frac{U_{actual}}{U_N}$

Example: U_{actual} = 400V 60Hz
U_N = 460V 60Hz
p_{oper. max.} = 0.85 p_{max.} · $\frac{400V}{460V}$ ≈ 0.7 p_{max.}

5.2 Motor protection circuitries and EMC

5.2.1 Protective motor switches

S1-operation: The bimetallic switch should be set for the corresponding current, required to achieve the adjusted pressure of the pressure limiting valve (see $I_{M-(pV)_{calc.}}$ - curve sect. 5.1), however not higher than the nom. current I_N . This motor protection covers only a possible mechanical blockade of the motor. The pressure limiting valve responses at pressure overload, without a rise beyond the corresponding motor current I_M . The pump would run on and on, resulting in an overheat after a certain time like any other hydraulic power pack of classic construction would do. Such a pressure overload can occur either due to overload of a consumer or start against a stop. This can be immediately identified as the consumer movement stops and also the idle signal would be missing (Idle circulation valve doesn't open in the idle periods). A permanent pressure monitoring via a pressure gauge helps to identify such a malfunction. It is therefore recommended to use a pressure switch for self-supervising of the idle periods especially for automatic, not permanently manned systems.

S6-operation: In most cases it is sufficient, to set the response current to approx. (0.85...0.9) of I_N . This makes sure that on one hand the bimetallic switch does not trigger too early during normal operation but on the other hand the oil temperature doesn't rise too high due to a prolonged response time after the pressure limiting valve is in action. Malfunctions during idle circulation mode, like described for S1-operation, are more reliably and immediately detected by idle supervising.

It has to be taken into account that these notes for adjustment only represent very coarse reference values and perhaps must be corrected a little during a definite test run of the system. This might occur e.g. if the actually required performance of the pump (in S6-operation) is higher than calculated. Too early triggering of the bimetallic switch will be caused as the temperature of the system would be higher after prolonged operation than anticipated thereby reducing the response period of the switch.

5.2.2 Temperature switch (acc. to sect. 3.3)

This is an optional monitoring device, which will cut-off the pump if the fluid temperature rises over 80°C due to any malfunction.

Examples: A pump is running too long against the pressure limiting valve at a unmanned system because the signal for idle circulation was not released. The response period will be too long due to the low current consumption.

The ambient temperature is too high, because it was not considered during lay-out of the system or it occurs unintended.

Too much heat is generated in the system because of additional throttle losses caused by flow control valves, pressure reducing valves, orifices etc.

Attention: The temperature switch will trigger only after the oil temperature is above approx. 95°C.

5.2.3 Float switch (acc. to sect. 3.3)

This is an optional monitoring device, which will either cut-off the pump or trigger a signal as soon as the fluid level drops below a certain level.

Examples: Line rupture will cause an immediate stop, preventing complete emptying of the tank and dry running of the pump. A signal will be triggered if the system was not refilled after design related fluid losses.

Attention: The signal has to be delayed sufficiently (time lag relay) if the lay-out of the system features an operation cycle where the pump is emptied below the min. level and replenished by the reflow from the consumer within one cycle.

5.2.4 Notes to ensure EMC (Electromagnetic compatibility)

The compact hydraulic power packs of HAWE are excluded by the EMC-regulation (§5, chapter 5) as they are no turn-key devices. We recommend the interference suppressors type 23140, 3 • 400 VAC 4 kW 50-60 Hz of Murr-Elektronik in D-71570 Oppenweiler, if any interferences should occur.

5.3 Heat built-up

The persistent service temperature is reached after approximately one hour of operating time.

Influence-factors: Pressure distribution during the load duration (middled pressure), share of the idle period, additional throttle losses, exceeding usual figures of back pressure for pipes and valves (pressure reducing valves, flow control valves, throttling valves, or throttles). These influences only have to be taken into account if they are effective for a longer period within the operating cycle (load duration).

The two most essential parameter, middled performance of the pump and load duration per operating cycle are usually sufficient for a rough re-check of the expected persistent fluid service temperature.

The curves below supply a rough guideline how far the persistent service temperature $\Delta\vartheta_B$ of the compact hydraulic power packs will settle above the ambient temperature ϑ_U .

$$\vartheta_{\text{fluid B}} = \Delta\vartheta_B + \vartheta_U$$

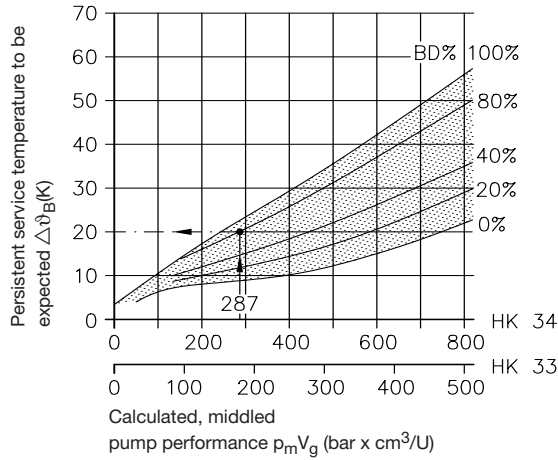

The $\Delta\vartheta_B - p_m V_g$ -curves below supply a rough guideline how far the persistent service temperature of the compact hydraulic power packs will settle above the ambient temperature, only covering usual figures of back pressure for pipes and valves.

The persistent service temperature will settle higher if additional throttle losses occur caused by e.g. pressure reducing valves, flow control valves, throttling valves, throttles or periodical start against the pressure limiting valve.

Working cycle

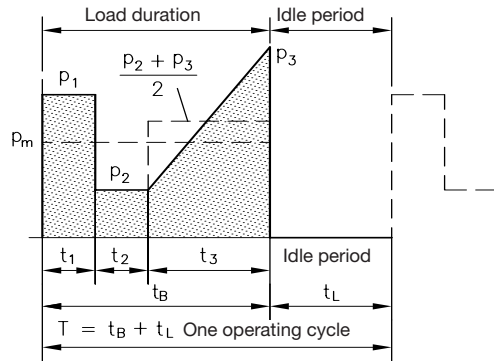

Calculation example: HK 34/1 - H2,5

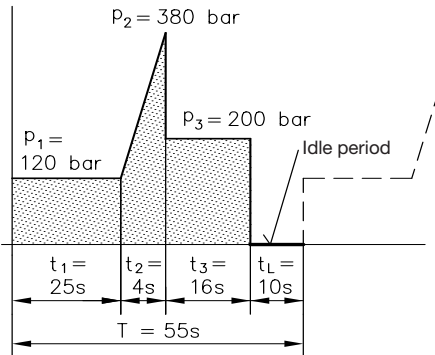

Given:

Pressure profile simplified down to easy geometric shape with cycle period T laid-off as abscissa.

Selected pump HK 34/1 - H2,5 with geom. displacement $V_g \cdot 1.79 \text{ cm}^3/\text{U}$

Pressure	Time
$p_1 = 120 \text{ bar}$	$t_1 = 25\text{s}$
$p_2 = 380 \text{ bar}$	$t_2 = 4\text{s}$
$p_3 = 200 \text{ bar}$	$t_3 = 16\text{s}$
$(p_L = 0 \text{ bar})$	$t_L = 10\text{s}$
	$\overline{T} = 55\text{s}$

$\vartheta_{\text{fluid B}}$ (°C) = Persistent service temperature of the oil filling
 $\Delta\vartheta_B$ (K) = Excess temperature after applied load, diagram
 ϑ_U (°C) = Ambient temperature in the installation area of the compact hydraulic power pack.

p_m (bar) = Calculated, middled pressure per cycle during the load duration $t_B = t_1 + t_2 + t_3 + \dots$

$$p_m \text{ (bar)} = \frac{1}{t_B} \left(p_1 \cdot t_1 + p_2 \cdot t_2 + \frac{p_2 + p_3}{2} \cdot t_3 + \dots \right)$$

$p_m V_g$ (bar·cm³/U) = Middled performance

with V_g = geom. displacement acc. to the tables in sect. 2.2 ++

%BD (-) = Relative load duration per operating cycle

$$\%BD = \frac{t_B}{t_B + t_L} \cdot 100$$

Calculated:

Middled pressure during the load duration $t_B = t_1 + t_2 + t_3 = 45\text{s}$

$$p_m = \frac{1}{t_B} \left(p_1 \cdot t_1 + \frac{p_1 + p_2}{2} \cdot t_2 + p_3 \cdot t_3 \right) = \frac{1}{45} \left(120 \cdot 25 + \frac{120 + 380}{2} \cdot 4 + 200 \cdot 16 \right) = 160 \text{ bar}$$

Middle value for pump performance $p_m V_g = 160 \cdot 1.79 \approx 287 \text{ bar} \cdot \text{cm}^3/\text{U}$

$$\text{Relative load duration } \%BD = \frac{t_B}{T} \cdot 100 = \frac{45}{55} \cdot 100 \approx 82\%$$

Resulting in $\Delta\vartheta_B$ 28 K from the $\Delta\vartheta_B - p_m V_g$ - curve

This means, that the persistent service temperature of the compact hydraulic power pack at an ambient temperature $\vartheta_U = 20^\circ\text{C}$ will be approx. $20 + 20 = 40^\circ\text{C}$ (under the pre-defined conditions and uninterrupted cycles)

5.4 Running noise

HK 3.. - H..

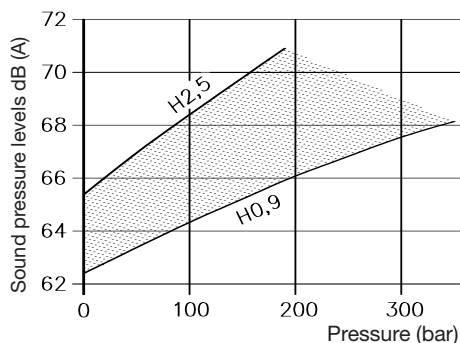

HK 3.. - Z..

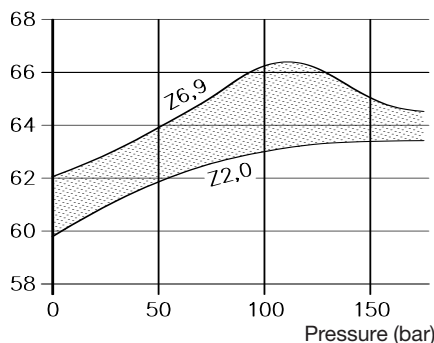

Measuring conditions: Work room, interference level approx. 50 dB(A); Measuring point 1m above the floor; 1m object clearance, pump fixed with 4 silentblocks Ø40x30 65 Shore, (Messrs. silentblocks No. 20291/V).

The sound pressure level ranges shall serve to estimate the running noise to be expected. They approximately delimit the spreads recognizable during measuring.

Measuring device: Precision sound pressure level measuring instrument DIN IEC 651 Kl. I

Rigid mounting on a surface capable of resonance (e.g. welded or thin-wall machine stands) may significantly amplify or conduct the operation noise level. We recommend to mount the compact hydraulic power pack via silentblocks e.g. Ø40x30, 65 Shore (see specifications of the measuring conditions).

Viscosity of the oil: Approx. 60 mm²/s

5.5 Auxiliary tanks

It is possible to increase the usable volume by connecting an auxiliary tank at port T. It should be used for volume compensation only. These tanks are to be customer furnished. The reflux pipe from the consumer circuit has to be connected at port R (connection pedestal)! The connection pipe has to be dimensioned sufficiently. The connection should be either by means of a hose only or with fittings for pipe 22x1.5 and a piece of hose to decouple the noise.

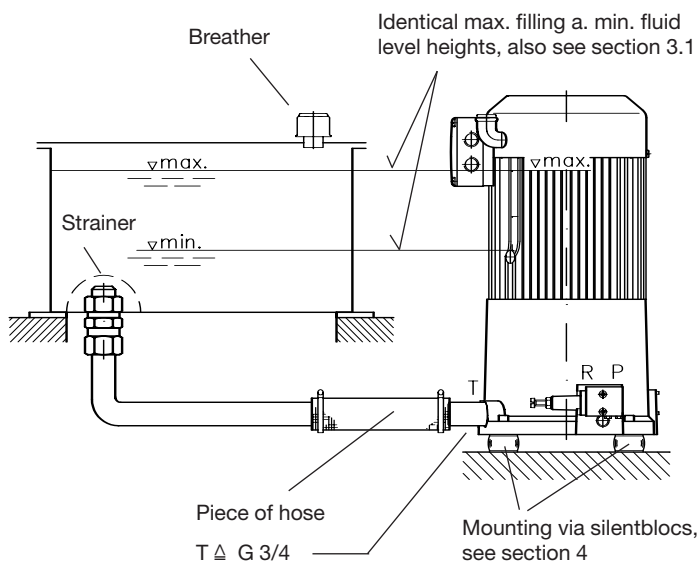

5.6 Connection blocks

The compact hydraulic power packs acc. to section 2 ++ only represent the basic versions. They will be ready for operation only after installation of appropriate connection blocks. Table 3 ++ below lists various connection blocks and the corresponding pamphlets which cover more detailed information as well as order examples.

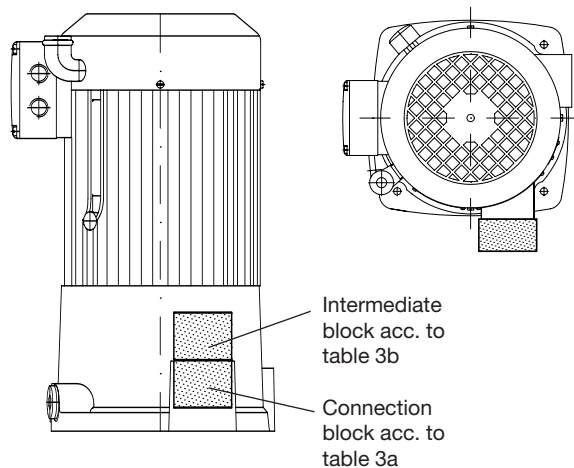

For selection table 3a and 3b, see page 12!

Table 3a: Connection blocks, overview

Pamphlet	Coding	Port threads DIN ISO 228/1	Pressure range from ... to (bar) ¹⁾	Flow (l/min)	Integrated functional elements ¹²⁾			Brief notes to the connection block	Suitable directional valve banks for direct mounting ¹⁾
					Pressure limiting valve	Idle cir- culation valve	Reflow filter		
D 6905 C	C5 C6	G 1/4 G 3/8	700 700	12 28	no no	no no	no no	Simple connection block	No possibility for mounting
D 6905 B	B../...-...	G 1/4 to G 1/2	450 (700)	8 ... 25	yes	no	no	For single acting lifting or clamping devices ^{1) 2)}	
D 6905 A/1	A1../.. to A4../..	G 1/4	(0) ... 700 in steps	12	yes	no	no	Most frequently used connection block with pressure limiting valve	①a) ①b)
	A13../.. to A43../..	G 3/8		18	yes	no	no		②
	A51../.. and A61../..	G 3/8		18	yes	no	no	More seldomly used for HK ³⁾	③
	AS(V)1../.. to AS(V)4../..	G 1/4	(0) ... 450 in steps	18	yes	yes	no	With idle circulation valves acc. to D 7490/1	①a) ①b)
	AL11(12)../..	G 1/4	51 ... 350 in steps	12	yes ⁴⁾	yes ⁴⁾	no	automatic idle circulation ⁴⁾ (accumula- tor charging valve)	①a) ⁸⁾
	A../F../.. AS../F../.. AM../F../.. AK../F../.. AL21F../.. AL21D../..	G 1/4 to G 1/2 dep. on type and connection side	(0) ... 700 in steps depending on type	15 ... 33 depending on filler size	yes ⁵⁾	yes ⁶⁾	yes ⁷⁾	With reflow filters 12 µm nom. 50% / 30 µm abs. or pressure resistant fil- ters 10 µm (β ₁₀ = 75) with AL21D../.. and idle circulation valves, see ⁶⁾	④ ⁸⁾
	AP1../.. and AP3../..	G 1/4	5 ... 700	20	yes	yes ⁹⁾	no	Proportional pressure limiting valve	①b) ①a)
D 6905 TÜV	AX14../.. and AX3../..	G 1/4	80 ... 450	6 ... 10	yes	no	no	Pressure limiting valve with unit approval	Add-on spool valves acc. to D 7230-1
D 7230-1 Pos. 8.1	SKC11../.. to SKC14../..	G 1/4 and G 3/8	200 .. 400 ¹⁰⁾	12 ... 20	yes	yes ¹¹⁾	no	Integrated directional spool valve	
D 7450	SWC1.../..	G 1/4	315	12	yes	yes ¹¹⁾	no	Integrated directional spool valve	Add-on spool valves acc. to D 7450

Table 3b: Additional intermediate blocks enabling arbitrary activation of a reduced pressure limitation lower than the main pressure

Pamphlet	Coding	Port threads DIN ISO 228/1	Pressure range from ... to (bar)	Integrated functional elements ¹²⁾ and brief description	Ongoing pipe connection
D 6905 A/1	V1../.. to S4../..	---	... 450	Pressure limiting valve and 2/2-way directional valve connected in series and acting as a by-pass P → R	Only via directly mounted directional valve bank ①a) ①b)

1) It should be kept in mind that the directional valve banks which can be directly mounted may have a max. permissible pressure below 700 bar.

2) Pumps type HK should be used for intermittent service only

3) The valves are directing radially to the outside

4) Hydraulic cut-off function acts as pressure limitation also

5) Depending on type also with additional proportional pressure limiting valve

6) Idle circulation valve acc. to D 7490/1 with AS../.., acc. to D 7470A/1 with AK../.. and AM../.., with automatic idle circulation (accumulator charging valve) with AL21../..

7) With pressure resistant filter at AL21../..D

8) Directional spool valve banks type SWR../.. are not ideally suited for mounting onto blocks type AL11(12) or AL21../.., as the their always apparent leakage would provoke permanent activation. This effect could be minimized by using an accumulator.

9) May be used as idle circulation valve if the prop. solenoid is deenergized (approx. 5 bar)

10) Depending on actuation and flow pattern

11) For directional spool valves with internal connection P→R in idle position

12) Pressure limiting valves acc. to D 7000E/1, 2/2-way directional valves acc. to D 7490/1, optional with additional check valve acc. to D 7445

①a) BWN(H)1F... acc. to D 7470 B/1

BWH2F... acc. to D 7470 B/1

BVZP1F... acc. to D 7785 B

①b) VB01(11)F... acc. to D 7302

SWR(P)1F... acc. to D 7450

D 7470 B/1

SWR2F... acc. to D 7451

② BWH3F... acc. to D 7470 B/1

③ VB11G../..and

VB21G../.. acc. to D 7302

④ BWN(H)1F... acc. to D 7470 B/1

BWH2F... acc. to D 7470 B/1

BVZP1F... acc. to D 7785 B

VB01(11)F... acc. to D 7302

SWR(P)1F... acc. to D 7450 ⁸⁾

D 7470 B/1⁸⁾

SWR2F... acc. to D 7451 ⁸⁾